



SKY HIGH LTD - THE TRAFFIC SURVEY COMPANY

AM 15 Minute Data Summary

Job :
Client : Peter Bretts Associates
Location : A2208 Rotherhithe New Road/Ilderton Road
Day : Thurs 09th July 2009
Weather : Fine
Peak Hour AM 7:30 AM to 8:30 AM

Vehicle Class Summary

Cats	Taxi	LGV	OGV1	OGV2	PSV	MC	Cycles
60.6%	1.9%	24.5%	3.9%	2.5%	1.1%	2.6%	2.9%

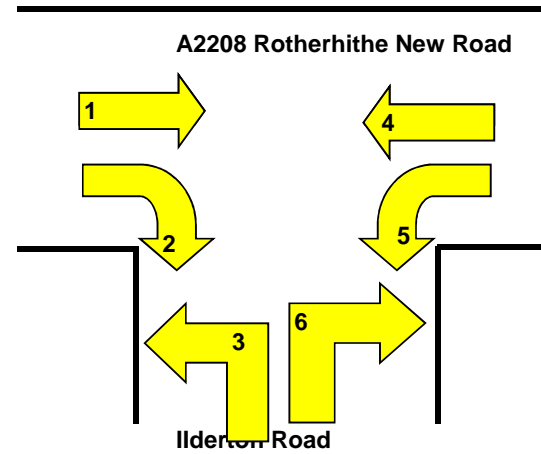

Time Period	Direction 1									Direction 2									Direction 3								
	Cars	Taxi	LGV	OGV1	OGV2	PSV	MC	Cycles	Total	Cars	Taxi	LGV	OGV1	OGV2	PSV	MC	Cycles	Total	Cars	Taxi	LGV	OGV1	OGV2	PSV	MC	Cycles	Total
07:00 to 07:15	67	0	27	2	1	1	2	2	102	24	1	19	2	2	1	3	4	56	32	2	31	3	4	1	0	2	75
07:15 to 07:30	84	2	26	3	2	0	3	1	121	30	2	14	1	1	2	2	1	53	38	3	22	2	4	2	2	1	74
07:30 to 07:45	77	2	22	2	1	1	2	5	112	24	14	14	2	2	1	3	2	62	32	2	24	2	1	1	2	3	67
07:45 to 08:00	100	0	34	1	2	0	2	3	142	22	0	17	2	1	2	1	3	48	37	2	15	1	1	2	1	1	60
08:00 to 08:15	88	4	34	2	1	0	5	4	138	16	1	6	1	1	1	1	2	29	38	1	12	4	2	1	1	4	63
08:15 to 08:30	94	2	29	2	3	1	2	4	137	24	1	13	1	1	2	0	1	43	29	0	16	1	2	2	3	2	55
08:30 to 08:45	69	2	23	1	1	0	2	1	99	29	2	11	3	2	1	1	1	50	22	1	15	1	2	2	3	1	47
08:45 to 09:00	128	3	36	2	1	1	2	2	175	34	1	13	2	1	2	1	1	55	25	3	15	3	1	2	0	3	52
09:00 to 09:15	85	2	32	3	2	0	2	6	132	32	2	14	0	1	4	2	0	55	32	3	19	3	2	2	2	3	66
09:15 to 09:30	87	3	25	3	1	1	3	5	128	19	1	16	3	1	4	1	1	46	23	2	22	2	1	1	0	2	53
09:30 to 09:45	65	2	32	4	1	2	2	3	111	16	2	7	2	2	2	1	0	32	30	3	18	4	1	1	0	1	58
09:45 to 10:00	72	1	26	3	2	3	1	2	110	24	2	19	7	2	6	3	2	65	16	1	15	3	4	3	1	3	46
Survey Total	1016	23	346	28	18	10	28	38	1507	294	29	163	26	17	28	19	18	594	354	23	224	29	25	20	15	26	716

Time Period	Direction 4									Direction 5									Direction 6								
	Cars	Taxi	LGV	OGV1	OGV2	PSV	MC	Cycles	Total	Cars	Taxi	LGV	OGV1	OGV2	PSV	MC	Cycles	Total	Cars	Taxi	LGV	OGV1	OGV2	PSV	MC	Cycles	Total
07:00 to 07:15	37	1	14	4	5	0	4	1	66	42	0	19	3	4	0	1	0	69	79	0	32	7	8	0	7	1	134
07:15 to 07:30	47	3	25	3	0	0	3	0	81	24	1	10	6	0	0	0	0	41	80	0	31	4	2	2	6	2	127
07:30 to 07:45	63	1	24	5	3	0	0	5	101	28	0	15	4	2	0	1	1	51	87	1	38	6	3	0	1	5	141
07:45 to 08:00	42	0	21	0	0	0	3	3	69	38	0	11	5	2	0	1	4	61	71	2	35	3	3	1	4	3	122
08:00 to 08:15	62	0	14	5	2	0	4	3	90	28	1	20	3	3	0	3	1	59	86	2	35	2	4	0	5	5	139
08:15 to 08:30	38	3	18	2	2	1	5	1	70	32	0	18	2	2	0	1	1	56	120	1	48	2	1	1	6	3	182
08:30 to 08:45	44	2	19	3	0	0	2	4	74	30	0	6	2	0	0	0	0	38	58	0	12	2	1	0	6	10	89
08:45 to 09:00	66	1	17	8	0	1	1	2	96	46	2	16	2	3	0	2	0	71	67	0	23	5	0	0	4	9	108
09:00 to 09:15	65	0	20	5	1	0	4	3	98	31	2	8	1	2	0	0	2	46	83	0	22	5	2	0	4	4	120
09:15 to 09:30	56	2	16	7	6	0	4	0	91	42	3	14	4	3	0	0	0	66	84	1	25	5	3	0	1	11	130
09:30 to 09:45	56	2	24	8	3	1	0	4	98	35	1	14	11	0	1	2	0	64	69	2	26	8	11	1	1	1	119
09:45 to 10:00	61	0	16	4	0	0	2	3	86	31	0	10	3	5	2	2	1	54	53	3	22	3	3	0	5	1	90
Survey Total	637	15	228	54	22	3	32	29	1020	407	10	161	46	26	3	13	10	676	937	12	349	52	41	5	50	55	1501

PM 15 Minute Data Summary

Job :
Client : Peter Bretts Associates
Location : A2208 Rotherhithe New Road/Ilderton Road
Day : Thurs 09th July 2009
Weather : Fine
Peak Hour PM 4:00 PM to 5:00 PM

Vehicle Class Summary							
Cars	MC	LGV	OGV	OGV	PSV	MC	Cycle
72.8%	1.0%	16.7%	2.2%	0.4%	1.0%	3.1%	2.7%

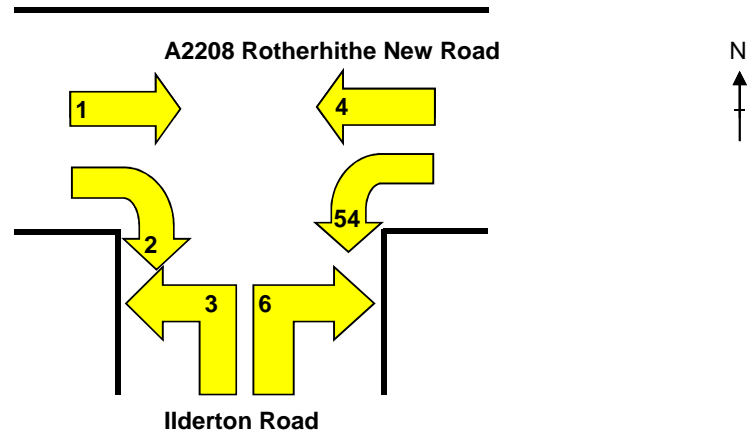

Time Period	Direction 1									Direction 2									Direction 3								
	Cars	Taxi	LGV	OGV1	OGV2	PSV	MC	Cycles	Total	Cars	Taxi	LGV	OGV1	OGV2	PSV	MC	Cycles	Total	Cars	Taxi	LGV	OGV1	OGV2	PSV	MC	Cycles	Total
16:00 to 16:15	98	1	53	2	1	1	2	2	160	25	0	29	5	0	3	6	1	69	20	2	10	1	1	3	0	3	40
16:15 to 16:30	116	1	35	4	0	0	1	1	158	41	0	20	2	1	0	2	0	66	37	0	5	4	0	2	4	0	52
16:30 to 16:45	98	0	24	0	1	1	3	3	130	33	0	17	2	0	0	2	1	55	23	1	6	2	1	4	0	2	39
16:45 to 17:00	127	1	41	4	1	1	2	2	179	31	1	21	1	0	2	1	1	58	36	0	11	4	1	2	0	0	54
17:00 to 17:15	95	0	20	3	2	2	1	2	125	26	1	17	1	0	1	2	2	50	28	1	6	0	0	5	0	0	40
17:15 to 17:30	106	0	23	1	1	1	3	1	136	35	1	15	2	1	2	2	3	61	39	0	6	2	1	3	1	1	53
17:30 to 17:45	91	0	27	3	0	1	3	4	129	45	0	10	2	0	2	2	4	65	22	3	6	1	0	0	2	2	36
17:45 to 18:00	87	0	18	1	1	0	5	1	113	40	3	12	0	0	1	3	1	60	29	1	2	3	0	1	3	1	40
18:00 to 18:15	88	1	11	1	0	1	1	4	107	46	1	17	0	0	1	1	4	70	35	0	8	1	0	0	2	1	47
18:15 to 18:30	84	2	14	0	0	0	2	5	107	26	1	9	2	0	2	4	5	49	33	1	3	0	0	2	5	0	44
18:30 to 18:45	86	0	7	1	1	0	1	4	100	45	0	11	0	0	1	1	3	61	38	0	1	2	0	1	0	0	42
18:45 to 19:00	81	1	5	0	1	0	3	3	94	39	1	9	1	0	1	3	5	59	27	1	3	1	1	1	1	0	35
Survey Total	1157	7	278	20	9	8	27	32	1538	432	9	187	18	2	16	29	30	723	367	10	67	21	5	24	18	10	522

Time Period	Direction 4									Direction 5									Direction 6								
	Cars	Taxi	LGV	OGV1	OGV2	PSV	MC	Cycles	Total	Cars	Taxi	LGV	OGV1	OGV2	PSV	MC	Cycles	Total	Cars	Taxi	LGV	OGV1	OGV2	PSV	MC	Cycles	Total
16:00 to 16:15	88	0	7	3	0	0	2	4	104	71	1	21	8	0	0	3	2	106	54	1	10	2	0	0	3	1	71
16:15 to 16:30	59	0	20	4	1	1	2	4	91	66	2	23	9	2	1	5	3	111	42	0	13	2	0	0	2	0	59
16:30 to 16:45	85	1	17	7	2	0	4	0	116	65	1	33	8	0	1	2	1	111	37	1	12	0	0	0	1	1	52
16:45 to 17:00	85	1	15	1	1	2	3	2	110	56	1	16	2	0	0	5	0	80	38	1	14	3	0	0	0	0	56
17:00 to 17:15	97	1	12	1	0	0	7	5	123	71	3	18	2	0	0	6	1	101	45	2	12	1	0	0	6	1	67
17:15 to 17:30	105	1	19	4	0	1	2	4	136	70	2	15	0	0	0	8	2	97	35	0	7	0	0	1	1	0	44
17:30 to 17:45	87	1	9	3	0	0	5	5	110	60	3	10	2	0	1	4	7	87	57	1	6	1	0	1	4	1	71
17:45 to 18:00	112	1	16	1	0	0	3	2	135	84	2	16	3	0	0	5	3	113	49	0	13	1	0	0	0	1	64
18:00 to 18:15	109	1	18	0	1	1	1	3	134	81	1	21	1	0	0	4	4	112	52	0	7	1	1	0	0	1	62
18:15 to 18:30	78	2	12	1	0	0	4	9	106	63	0	11	0	0	0	9	4	87	51	0	4	0	0	0	0	0	55
18:30 to 18:45	80	0	10	0	0	1	0	2	93	70	1	14	0	0	1	2	8	96	72	0	11	0	0	0	4	0	87
18:45 to 19:00	76	0	6	1	1	0	2	5	91	54	2	5	1	0	0	4	5	71	39	1	7	0	0	0	1	3	51
Survey Total	1061	9	161	26	6	6	35	45	1349	811	19	203	36	2	4	57	40	1172	571	7	116	11	1	2	22	9	739

AM Hourly Summary

Job :
Client : Peter Bretts Associates
Location : A2208 Rotherhithe New Road/Ilderton Road
Day : Thurs 09th July 2009
Weather : Fine
Peak Hour AM 7:30 AM to 8:30 AM
Peak Hour PM 4:00 PM to 5:00PM

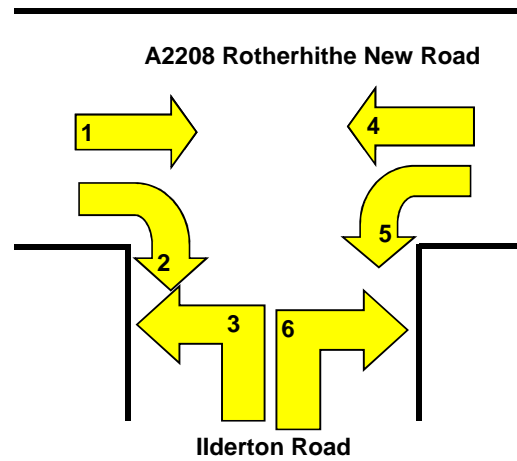

Time Period			Direction 1								Direction 2								Direction 3										
			Cars	Taxi	LGV	OGV1	OGV2	PSV	MC	Cycles	Total	Cars	Taxi	LGV	OGV1	OGV2	PSV	MC	Cycles	Total	Cars	Taxi	LGV	OGV1	OGV2	PSV	MC	Cycles	Total
07:00	to	08:00	328	4	109	8	6	2	9	11	477	100	17	64	7	6	6	9	10	219	139	9	92	8	10	6	5	7	276
07:15	to	08:15	349	8	116	8	6	1	12	13	513	92	17	51	6	5	6	7	8	192	145	8	73	9	8	6	6	9	264
07:30	to	08:30	359	8	119	7	7	2	11	16	529	86	16	50	6	5	6	5	8	182	136	5	67	8	6	6	7	10	245
07:45	to	08:45	351	8	120	6	7	1	11	12	516	91	4	47	7	5	6	3	7	170	126	4	58	7	7	7	8	8	225
08:00	to	09:00	379	11	122	7	6	2	11	11	549	103	5	43	7	5	6	3	5	177	114	5	58	9	7	7	7	10	217
08:15	to	09:15	376	9	120	8	7	2	8	13	543	119	6	51	6	5	9	4	3	203	108	7	65	8	7	8	8	9	220
08:30	to	09:30	369	10	116	9	5	2	9	14	534	114	6	54	8	5	11	5	3	206	102	9	71	9	6	7	5	9	218
08:45	to	09:45	365	10	125	12	5	4	9	16	546	101	6	50	7	5	12	5	2	188	110	11	74	12	5	6	2	9	229
09:00	to	10:00	309	8	115	13	6	6	8	16	481	91	7	56	12	6	16	7	3	198	101	9	74	12	8	7	3	9	223

Time Period			Direction 4								Direction 5								Direction 6										
			Cars	Taxi	LGV	OGV1	OGV2	PSV	MC	Cycles	Total	Cars	Taxi	LGV	OGV1	OGV2	PSV	MC	Cycles	Total	Cars	Taxi	LGV	OGV1	OGV2	PSV	MC	Cycles	Total
07:00	to	08:00	189	5	84	12	8	0	10	9	317	132	1	55	18	8	0	3	5	222	317	3	136	20	16	3	18	11	524
07:15	to	08:15	214	4	84	13	5	0	10	11	341	118	2	56	18	7	0	5	6	212	324	5	139	15	12	3	16	15	529
07:30	to	08:30	205	4	77	12	7	1	12	12	330	126	1	64	14	9	0	6	7	227	364	6	156	13	11	2	16	16	584
07:45	to	08:45	186	5	72	10	4	1	14	11	303	128	1	55	12	7	0	5	6	214	335	5	130	9	9	2	21	21	532
08:00	to	09:00	210	6	68	18	4	2	12	10	330	136	3	60	9	8	0	6	2	224	331	3	118	11	6	1	21	27	518
08:15	to	09:15	213	6	74	18	3	2	12	10	338	139	4	48	7	7	0	3	3	211	328	1	105	14	4	1	20	26	499
08:30	to	09:30	231	5	72	23	7	1	11	9	359	149	7	44	9	8	0	2	2	221	292	1	82	17	6	0	15	34	447
08:45	to	09:45	243	5	77	28	10	2	9	9	383	154	8	52	18	8	1	4	2	247	303	3	96	23	16	1	10	25	477
09:00	to	10:00	238	4	76	24	10	1	10	10	373	139	6	46	19	10	3	4	3	230	289	6	95	21	19	1	11	17	459

PM Hourly Summary

Time Period			Direction 1								Direction 2								Direction 3										
			Cars	Taxi	LGV	OGV1	OGV2	PSV	MC	Cycles	Total	Cars	Taxi	LGV	OGV1	OGV2	PSV	MC	Cycles	Total	Cars	Taxi	LGV	OGV1	OGV2	PSV	MC	Cycles	Total
16:00	to	17:00	439	3	153	10	3	3	8	8	627	130	1	87	10	1	5	11	3	248	116	3	32	11	3	11	4	5	185
16:15	to	17:15	436	2	120	11	4	4	7	8	592	131	2	75	6	1	3	7	4	229	124	2	28	10	2	13	4	2	185
16:30	to	17:30	426	1	108	8	5	5	9	8	570	125	3	70	6	1	5	7	7	224	126	2	29	8	3	14	1	3	186
16:45	to	17:45	419	1	111	11	4	5	9	9	569	137	3	63	6	1	7	7	10	234	125	4	29	7	2	10	3	3	183
17:00	to	18:00	379	0	88	8	4	4	12	8	503	146	5	54	5	1	6	9	10	236	118	5	20	6	1	9	6	4	169
17:15	to	18:15	372	1	79	6	2	3	12	10	485	166	5	54	4	1	6	8	12	256	125	4	22	7	1	4	8	5	176
17:30	to	18:30	350	3	70	5	1	2	11	14	456	157	5	48	4	0	6	10	14	244	119	5	19	5	0	3	12	4	167
17:45	to	18:45	345	3	50	3	2	1	9	14	427	157	5	49	2	0	5	9	13	240	135	2	14	6	0	4	10	2	173
18:00	to	19:00	339	4	37	2	2	1	7	16	408	156	3	46	3	0	5	9	17	239	133	2	15	4	1	4	8	1	168

PM Hourly Summary

Time Period			Direction 4								Direction 5								Direction 6										
			Cars	Taxi	LGV	OGV1	OGV2	PSV	MC	Cycles	Total	Cars	Taxi	LGV	OGV1	OGV2	PSV	MC	Cycles	Total	Cars	Taxi	LGV	OGV1	OGV2	PSV	MC	Cycles	Total
16:00	to	17:00	317	2	59	15	4	3	11	10	421	258	5	93	27	2	2	15	6	408	171	3	49	7	0	0	6	2	238
16:15	to	17:15	326	3	64	13	4	3	16	11	440	258	7	90	21	2	2	18	5	403	162	4	51	6	0	0	9	2	234
16:30	to	17:30	372	4	63	13	3	3	16	11	485	262	7	82	12	0	1	21	4	389	155	4	45	4	0	1	8	2	219
16:45	to	17:45	374	4	55	9	1	3	17	16	479	257	9	59	6	0	1	23	10	365	175	4	39	5	0	2	11	2	238
17:00	to	18:00	401	4	56	9	0	1	17	16	504	285	10	59	7	0	1	23	13	398	186	3	38	3	0	2	11	3	246
17:15	to	18:15	413	4	62	8	1	2	11	14	515	295	8	62	6	0	1	21	16	409	193	1	33	3	1	2	5	3	241
17:30	to	18:30	386	5	55	5	1	1	13	19	485	288	6	58	6	0	1	22	18	399	209	1	30	3	1	1	4	3	252
17:45	to	18:45	379	4	56	2	1	2	8	16	468	298	4	62	4	0	1	20	19	408	224	0	35	2	1	0	4	2	268
18:00	to	19:00	343	3	46	2	2	2	7	19	424	268	4	51	2	0	1	19	21	366	214	1	29	1	1	0	5	4	255



SKY HIGH LTD - THE TRAFFIC SURVEY COMPANY

Job :
Client : Peter Bretts Associates
Location : A2208 Rotherhithe New Road/Ilderton R
Day : Thurs 09th July 2009
Weather : Fine
Peak Hour AM : 7:30 AM to 8:30 AM
Peak Hour PM : 4:00 PM to 5:00 PM

Choose Time Period

7:00 to 8:00

- = Total number by direction
- = Total number of inbound and outbound traffic flows

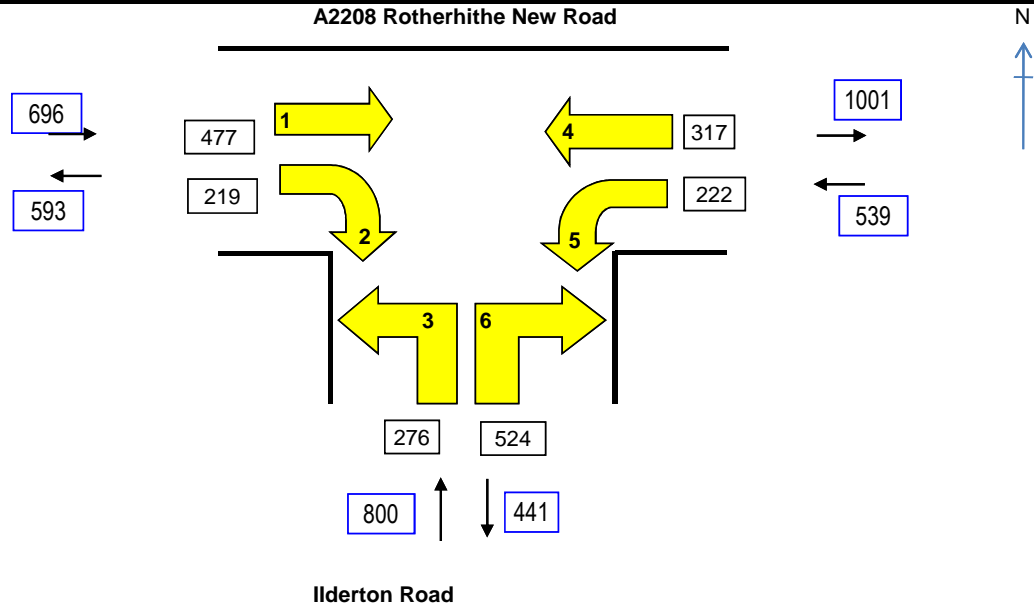



SKY HIGH LTD - THE TRAFFIC SURVEY COMPANY

15 Minute Data Summary			
Job no	:		
Client	:	Peter Bretts Associates	
Location	:	Ilderton Road/Zampa Road/Verney Road	
Date	:	Thurs 09th July 2009	
Weather	:	Fine	
Peak Hour AM		8:30 AM to	9:30 AM
Peak Hour PM		5:45 PM to	6:45 PM

Verney Road

Vehicle Class Summary							
Cars	Taxi	LGV	OGV1	OGV2	PSV	MC	Cycles
68.1%	1.3%	17.1%	4.7%	1.2%	0.9%	2.7%	4.1%

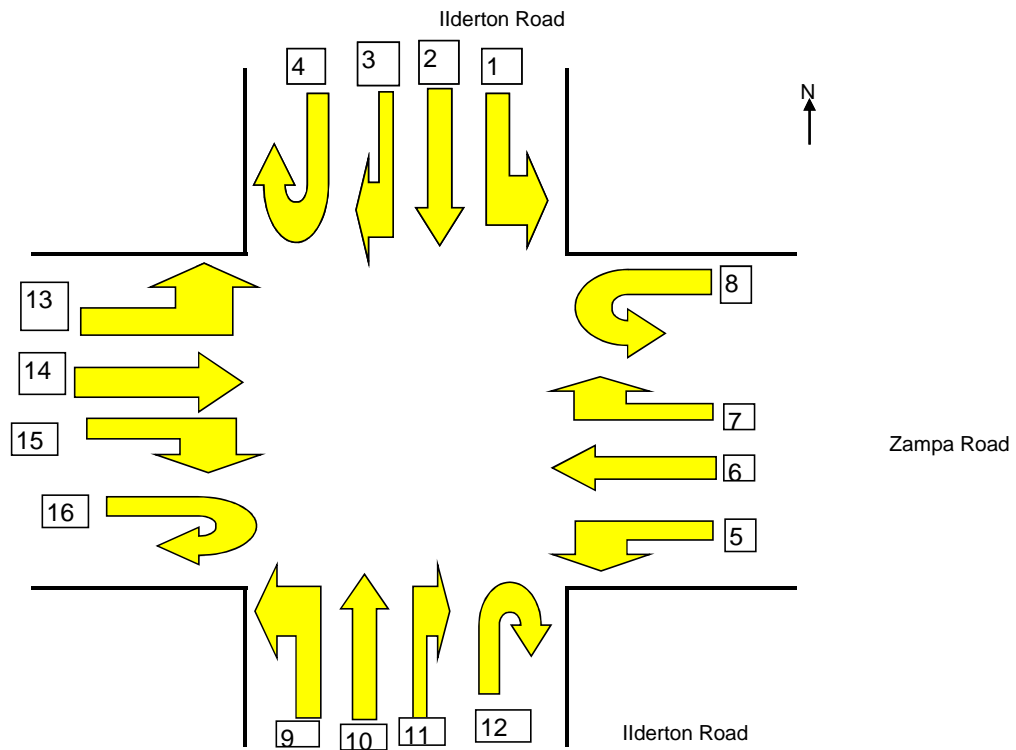

Hourly Summary

Job no :
Client : Peter Bretts Associates
Location : Ilderton Road/Zampa Road/Verney Road
Weather : Thurs 09th July 2009
Peak Hour AM : Fine to 12:00 AM

Verney Road

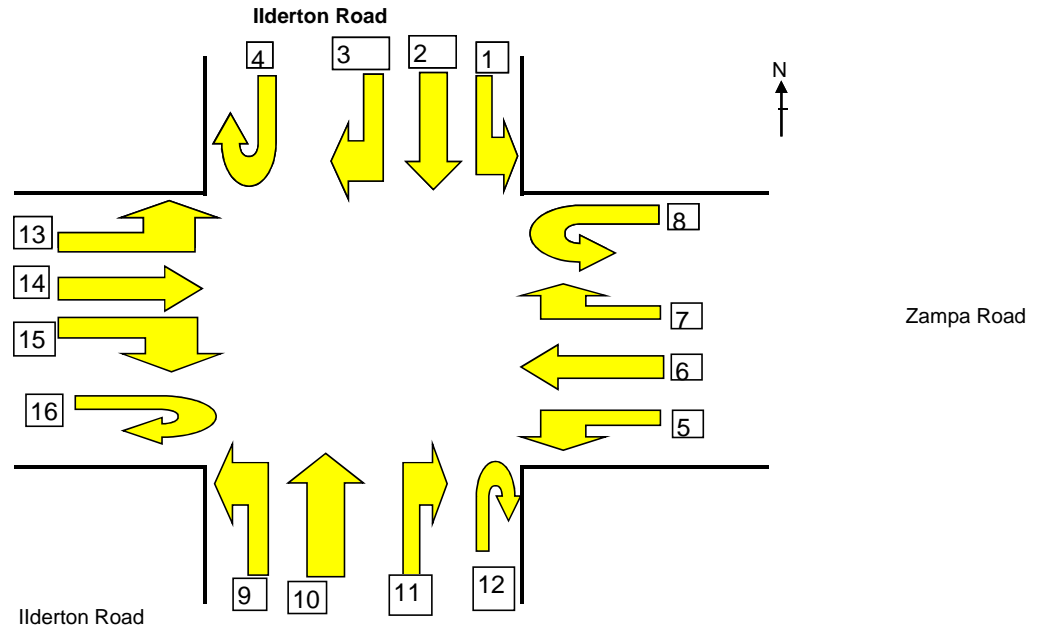



SKY HIGH LTD - THE TRAFFIC SURVEY COMPANY

AM 15 Minute Data Summary			
Job no	:		
Client	: Peter Bretts Associates		
Location	: Ilderton Road/Zampa Road/Verney Road		
Date	: Thurs 09th July 2009		
Weather	: Fine		
Peak Hour	8:30 AM	to	9:30 AM
	5:45 PM		6:45 PM

Choose Time Period

7:00 to 8:00

= Total number by direction

= Total number of inbound and outbound traffic flows

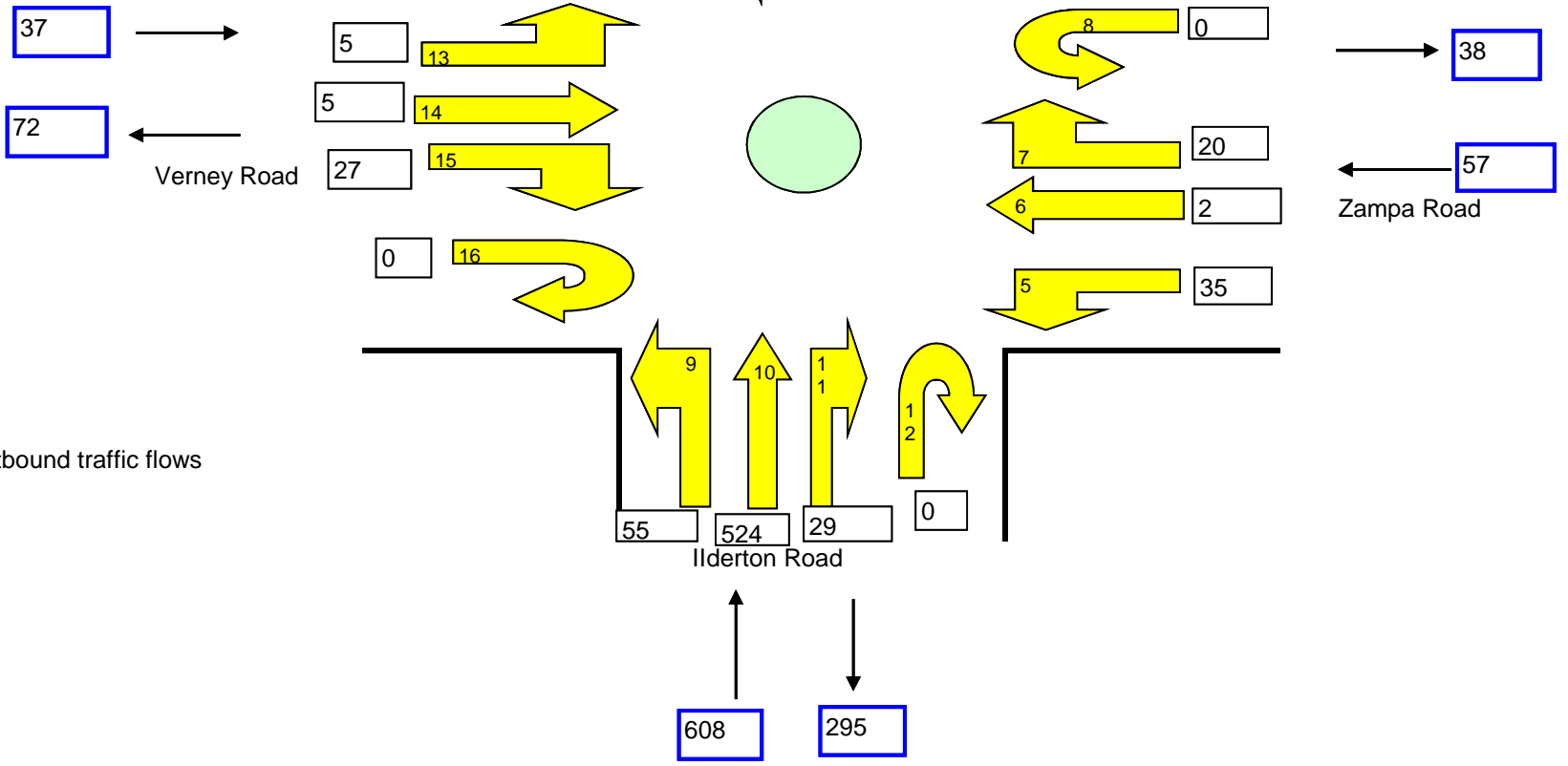



SKY HIGH LTD - THE TRAFFIC SURVEY COMPANY

AM 15 Minute Data Summary

Job :
Client : Peter Bretts Associates
Location : Ilderton Road/Surrey Canal Road
Day : Thurs 09th July 2009
Weather : Fine
Peak Hour AM 7:45 AM to 8:45 AM

Vehicle Class Summary

Cars	Taxi	LGV	OGV1	OGV2	PSV	MC	Cycles
58.3%	1.3%	21.5%	4.8%	5.6%	1.4%	2.9%	4.2%

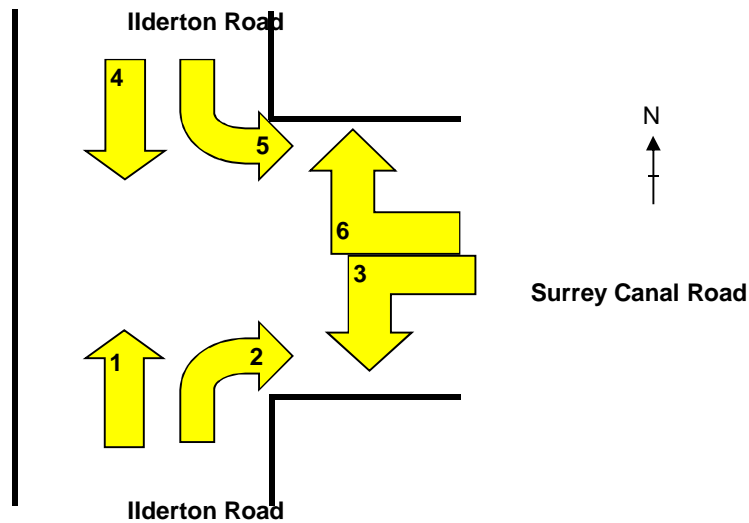

Time Period	Direction 1									Direction 2									Direction 3								
	Cars	Taxi	LGV	OGV1	OGV2	PSV	MC	Cycles	Total	Cars	Taxi	LGV	OGV1	OGV2	PSV	MC	Cycles	Total	Cars	Taxi	LGV	OGV1	OGV2	PSV	MC	Cycles	Total
07:00 to 07:15	62	1	28	4	4	1	5	2	107	13	1	3	0	1	0	1	0	19	8	0	5	5	2	0	1	2	23
07:15 to 07:30	70	0	22	8	1	3	4	1	109	12	0	8	4	1	0	0	0	25	24	0	4	3	1	0	3	0	35
07:30 to 07:45	80	1	29	2	3	2	1	4	122	14	2	3	2	4	0	2	1	28	18	1	5	5	1	0	0	0	30
07:45 to 08:00	88	2	25	4	1	3	1	2	126	18	0	9	3	2	0	1	0	33	13	0	3	3	2	0	2	0	23
08:00 to 08:15	68	2	22	4	3	1	4	3	107	21	1	7	2	2	0	1	0	34	12	1	5	2	2	0	1	0	23
08:15 to 08:30	101	1	22	2	1	1	5	6	139	13	0	3	3	4	0	1	0	24	12	1	6	5	2	0	1	0	27
08:30 to 08:45	102	1	30	2	3	2	9	7	156	16	2	6	3	1	0	1	0	29	15	0	8	7	0	0	3	0	33
08:45 to 09:00	57	0	16	3	2	2	7	6	93	14	1	7	2	0	0	1	0	25	9	0	5	4	3	0	1	0	22
09:00 to 09:15	79	1	23	4	1	2	4	2	116	17	0	10	1	2	0	1	0	31	11	1	10	2	1	0	0	0	25
09:15 to 09:30	77	2	22	1	4	1	1	4	112	14	2	9	2	3	0	0	0	30	24	1	7	3	2	0	0	0	37
09:30 to 09:45	66	1	22	5	4	2	1	1	102	17	2	10	5	1	0	0	0	35	17	0	10	1	1	0	0	0	29
09:45 to 10:00	62	5	21	6	1	2	5	4	106	17	0	7	9	5	0	0	0	38	19	1	7	1	0	0	2	0	30
Survey Total	912	17	282	45	28	22	47	42	1395	186	11	82	36	26	0	9	1	351	182	6	75	41	17	0	14	2	337

Time Period	Direction 4									Direction 5									Direction 6								
	Cars	Taxi	LGV	OGV1	OGV2	PSV	MC	Cycles	Total	Cars	Taxi	LGV	OGV1	OGV2	PSV	MC	Cycles	Total	Cars	Taxi	LGV	OGV1	OGV2	PSV	MC	Cycles	Total
07:00 to 07:15	29	0	10	1	0	1	2	0	43	17	0	6	6	1	0	1	0	31	57	0	23	2	11	1	3	1	98
07:15 to 07:30	18	1	9	1	4	2	0	1	36	14	0	4	1	4	1	1	2	27	56	0	24	4	3	0	2	8	97
07:30 to 07:45	20	0	11	3	5	2	2	1	44	20	2	9	3	3	1	0	3	41	40	0	36	4	6	0	3	6	95
07:45 to 08:00	23	0	15	1	3	3	0	0	45	21	0	9	3	2	0	1	3	39	40	0	20	3	6	0	1	10	80
08:00 to 08:15	27	1	13	1	4	1	2	1	50	15	0	7	1	1	0	0	1	25	40	0	12	1	7	1	2	10	73
08:15 to 08:30	22	0	5	0	0	2	0	0	29	26	0	4	1	3	1	1	0	36	23	0	9	0	3	0	4	23	62
08:30 to 08:45	23	2	14	0	3	3	1	0	46	40	0	5	1	6	1	0	2	55	42	0	14	2	2	0	5	13	78
08:45 to 09:00	27	1	11	0	2	1	0	0	42	53	0	8	2	3	0	1	1	68	23	2	10	0	5	0	0	8	48
09:00 to 09:15	24	2	13	3	4	3	1	1	51	25	0	7	1	3	1	0	0	37	29	0	13	3	5	0	3	5	58
09:15 to 09:30	23	4	10	5	7	2	0	1	52	20	0	6	4	6	0	0	1	37	32	0	17	0	4	0	3	10	66
09:30 to 09:45	33	1	13	2	0	3	1	0	53	27	1	7	2	3	0	1	0	41	39	0	16	0	15	0	0	7	77
09:45 to 10:00	28	0	0	2	5	3	0	2	40	24	1	13	4	8	0	2	1	53	22	0	13	1	5	1	4	2	48
Survey Total	297	12	124	19	37	26	9	7	531	302	4	85	29	43	5	8	14	490	443	2	207	20	72	3	30	103	880

PM 15 Minute Data Summary

Job :
 Client : Peter Bretts Associates
 Location : Ilderton Road/Surrey Canal Road
 Day : Thurs 09th July 2009
 Weather : Fine
 Peak Hour PM 5:45 PM to 6:45 PM

Vehicle Class Summary							
Cars	MC	LGV	OGV	OGV	PSV	MC	Cycle
69.4%	1.2%	17.1%	2.5%	1.0%	1.3%	3.3%	4.2%

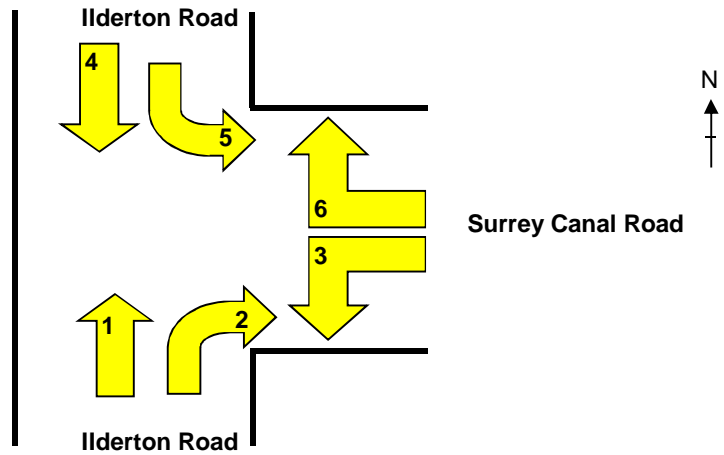

Time Period	Direction 1									Direction 2									Direction 3								
	Cars	Taxi	LGV	OGV1	OGV2	PSV	MC	Cycles	Total	Cars	Taxi	LGV	OGV1	OGV2	PSV	MC	Cycles	Total	Cars	Taxi	LGV	OGV1	OGV2	PSV	MC	Cycles	Total
16:00 to 16:15	36	0	12	1	0	2	2	0	53	32	0	4	3	1	0	0	0	40	20	0	8	2	0	1	0	0	31
16:15 to 16:30	37	0	10	0	0	0	1	1	49	33	0	9	2	0	0	1	0	45	30	1	5	0	1	0	1	0	38
16:30 to 16:45	38	1	6	2	1	5	1	2	56	39	0	16	4	1	0	0	1	61	33	1	3	1	0	0	2	0	40
16:45 to 17:00	29	2	9	3	1	1	1	1	47	40	0	14	2	0	0	1	1	58	36	0	11	3	0	0	1	0	51
17:00 to 17:15	26	1	4	1	0	1	1	2	36	37	0	12	2	0	0	2	1	54	39	0	3	1	11	0	1	0	55
17:15 to 17:30	42	1	7	2	0	3	3	1	59	52	0	11	6	0	0	1	0	70	35	0	4	0	0	0	0	0	39
17:30 to 17:45	51	3	5	2	0	1	5	2	69	51	0	11	2	0	0	3	0	67	38	0	4	2	0	0	1	4	49
17:45 to 18:00	33	0	8	0	0	2	2	2	47	35	0	11	3	0	0	0	0	49	34	0	3	0	1	0	3	1	42
18:00 to 18:15	40	1	5	1	0	0	1	5	53	64	0	11	1	0	0	2	0	78	41	0	2	0	0	0	4	2	49
18:15 to 18:30	45	0	3	0	0	2	1	1	52	21	0	7	1	0	0	0	0	29	38	0	6	0	0	0	4	2	50
18:30 to 18:45	57	2	9	0	0	1	4	2	75	35	2	15	1	0	11	1	0	65	43	0	5	0	1	0	0	0	49
18:45 to 19:00	53	0	8	2	1	1	0	1	66	41	0	6	1	0	0	2	0	50	40	1	4	0	0	1	1	1	48
Survey Total	487	11	86	14	3	19	22	20	662	480	2	127	28	2	11	13	3	666	427	3	58	9	14	2	18	10	541

Time Period	Direction 4									Direction 5									Direction 6								
	Cars	Taxi	LGV	OGV1	OGV2	PSV	MC	Cycles	Total	Cars	Taxi	LGV	OGV1	OGV2	PSV	MC	Cycles	Total	Cars	Taxi	LGV	OGV1	OGV2	PSV	MC	Cycles	Total
16:00 to 16:15	42	0	1	2	1	0	2	2	50	74	0	55	5	5	0	6	1	146	29	2	10	2	1	0	0	1	45
16:15 to 16:30	35	3	7	4	0	4	1	2	56	82	1	49	6	3	1	1	4	147	28	0	3	1	2	0	2	0	36
16:30 to 16:45	43	0	9	8	0	1	3	0	64	84	1	43	5	2	0	3	6	144	21	0	6	1	0	0	0	0	28
16:45 to 17:00	35	0	8	2	0	1	4	1	51	88	3	35	3	0	3	5	1	138	25	0	3	1	2	2	1	3	37
17:00 to 17:15	47	2	12	1	0	1	4	2	69	88	2	38	4	1	2	5	10	150	32	1	5	0	0	0	2	3	43
17:15 to 17:30	35	2	11	1	1	1	5	2	58	89	0	40	3	1	0	2	4	139	28	0	5	0	0	0	2	5	40
17:30 to 17:45	39	2	8	1	0	2	3	4	59	91	3	20	1	4	1	9	9	138	21	0	8	0	0	0	1	6	36
17:45 to 18:00	60	1	8	0	0	2	2	5	78	96	4	37	4	0	0	6	13	160	42	0	4	0	2	0	2	2	52
18:00 to 18:15	47	0	9	1	2	2	3	2	66	89	1	26	1	0	0	2	15	134	24	0	5	0	0	0	0	2	31
18:15 to 18:30	48	3	10	1	0	3	7	1	73	83	2	23	4	0	0	6	20	138	30	1	2	0	0	0	4	1	38
18:30 to 18:45	65	0	6	0	0	3	1	2	77	88	1	20	2	0	0	3	13	127	43	0	5	2	0	0	1	3	54
18:45 to 19:00	41	3	4	0	0	2	2	2	54	92	1	16	2	0	0	5	18	134	34	1	0	0	1	1	1	2	40
Survey Total	537	16	93	21	4	22	37	25	755	1044	19	402	40	16	7	53	114	1695	357	5	56	7	8	3	16	28	480

AM Hourly Summary

Job :
Client : Peter Bretts Associates
Location : Ilderton Road/Surrey Canal Road
Day : Thurs 09th July 2009
Weather : Fine
Peak Hour AM 7:45 AM to 8:45 AM
Peak Hour PM 5:45 PM to 5:00PM

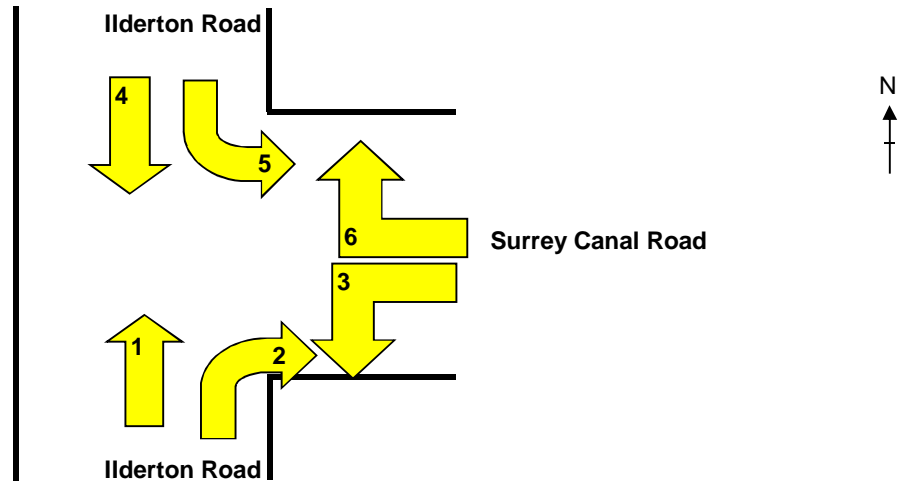

			Direction 1								Direction 2								Direction 3										
Time Period			Cars	Taxi	LGV	OGV1	OGV2	PSV	MC	Cycles	Total	Cars	Taxi	LGV	OGV1	OGV2	PSV	MC	Cycles	Total	Cars	Taxi	LGV	OGV1	OGV2	PSV	MC	Cycles	Total
07:00	to	08:00	300	4	104	18	9	9	11	9	464	57	3	23	9	8	0	4	1	105	63	1	17	16	6	0	6	2	111
07:15	to	08:15	306	5	98	18	8	9	10	10	464	65	3	27	11	9	0	4	1	120	67	2	17	13	6	0	6	0	111
07:30	to	08:30	337	6	98	12	8	7	11	15	494	66	3	22	10	12	0	5	1	119	55	3	19	15	7	0	4	0	103
07:45	to	08:45	359	6	99	12	8	7	19	18	528	68	3	25	11	9	0	4	0	120	52	2	22	17	6	0	7	0	106
08:00	to	09:00	328	4	90	11	9	6	25	22	495	64	4	23	10	7	0	4	0	112	48	2	24	18	7	0	6	0	105
08:15	to	09:15	339	3	91	11	7	7	25	21	504	60	3	26	9	7	0	4	0	109	47	2	29	18	6	0	5	0	107
08:30	to	09:30	315	4	91	10	10	7	21	19	477	61	5	32	8	6	0	3	0	115	59	2	30	16	6	0	4	0	117
08:45	to	09:45	279	4	83	13	11	7	13	13	423	62	5	36	10	6	0	2	0	121	61	2	32	10	7	0	1	0	113
09:00	to	10:00	284	9	88	16	10	7	11	11	436	65	4	36	17	11	0	1	0	134	71	3	34	7	4	0	2	0	121

			Direction 4									Direction 5									Direction 6								
Time Period			Cars	Taxi	LGV	OGV1	OGV2	PSV	MC	Cycles	Total	Cars	Taxi	LGV	OGV1	OGV2	PSV	MC	Cycles	Total	Cars	Taxi	LGV	OGV1	OGV2	PSV	MC	Cycles	Total
07:00	to	08:00	90	1	45	6	12	8	4	2	168	72	2	28	13	10	2	3	8	138	193	0	103	13	26	1	9	25	370
07:15	to	08:15	88	2	48	6	16	8	4	3	175	70	2	29	8	10	2	2	9	132	176	0	92	12	22	1	8	34	345
07:30	to	08:30	92	1	44	5	12	8	4	2	168	82	2	29	8	9	2	2	7	141	143	0	77	8	22	1	10	49	310
07:45	to	08:45	95	3	47	2	10	9	3	1	170	102	0	25	6	12	2	2	6	155	145	0	55	6	18	1	12	56	293
08:00	to	09:00	99	4	43	1	9	7	3	1	167	134	0	24	5	13	2	2	4	184	128	2	45	3	17	1	11	54	261
08:15	to	09:15	96	5	43	3	9	9	2	1	168	144	0	24	5	15	3	2	3	196	117	2	46	5	15	0	12	49	246
08:30	to	09:30	97	9	48	8	16	9	2	2	191	138	0	26	8	18	2	1	4	197	126	2	54	5	16	0	11	36	250
08:45	to	09:45	107	8	47	10	13	9	2	2	198	125	1	28	9	15	1	2	2	183	123	2	56	3	29	0	6	30	249
09:00	to	10:00	108	7	36	12	16	11	2	4	196	96	2	33	11	20	1	3	2	168	122	0	59	4	29	1	10	24	249

PM Hourly Summary

Time Period			Direction 1								Direction 2								Direction 3										
			Cars	Taxi	LGV	OGV1	OGV2	PSV	MC	Cycles	Total	Cars	Taxi	LGV	OGV1	OGV2	PSV	MC	Cycles	Total	Cars	Taxi	LGV	OGV1	OGV2	PSV	MC	Cycles	Total
16:00	to	17:00	140	3	37	6	2	8	5	4	205	144	0	43	11	2	0	2	2	204	119	2	27	6	1	1	4	0	160
16:15	to	17:15	130	4	29	6	2	7	4	6	188	149	0	51	10	1	0	4	3	218	138	2	22	5	12	0	5	0	184
16:30	to	17:30	135	5	26	8	2	10	6	6	198	168	0	53	14	1	0	4	3	243	143	1	21	5	11	0	4	0	185
16:45	to	17:45	148	7	25	8	1	6	10	6	211	180	0	48	12	0	0	7	2	249	148	0	22	6	11	0	3	4	194
17:00	to	18:00	152	5	24	5	0	7	11	7	211	175	0	45	13	0	0	6	1	240	146	0	14	3	12	0	5	5	185
17:15	to	18:15	166	5	25	5	0	6	11	10	228	202	0	44	12	0	0	6	0	264	148	0	13	2	1	0	8	7	179
17:30	to	18:30	169	4	21	3	0	5	9	10	221	171	0	40	7	0	0	5	0	223	151	0	15	2	1	0	12	9	190
17:45	to	18:45	175	3	25	1	0	5	8	10	227	155	2	44	6	0	11	3	0	221	156	0	16	0	2	0	11	5	190
18:00	to	19:00	195	3	25	3	1	4	6	9	246	161	2	39	4	0	11	5	0	222	162	1	17	0	1	1	9	5	196

PM Hourly Summary

Time Period	Direction 4										Direction 5										Direction 6									
	Cars	Taxi	LGV	OGV1	OGV2	PSV	MC	Cycles	Total	Cars	Taxi	LGV	OGV1	OGV2	PSV	MC	Cycles	Total	Cars	Taxi	LGV	OGV1	OGV2	PSV	MC	Cycles	Total			
16:00 to 17:00	155	3	25	16	1	6	10	5	221	328	5	182	19	10	4	15	12	575	103	2	22	5	5	2	3	4	146			
16:15 to 17:15	160	5	36	15	0	7	12	5	240	342	7	165	18	6	6	14	21	579	106	1	17	3	4	2	5	6	144			
16:30 to 17:30	160	4	40	12	1	4	16	5	242	349	6	156	15	4	5	15	21	571	106	1	19	2	2	2	5	11	148			
16:45 to 17:45	156	6	39	5	1	5	16	9	237	356	8	133	11	6	6	21	24	565	106	1	21	1	2	2	6	17	156			
17:00 to 18:00	181	7	39	3	1	6	14	13	264	364	9	135	12	6	3	22	36	587	123	1	22	0	2	0	7	16	171			
17:15 to 18:15	181	5	36	3	3	7	13	13	261	365	8	123	9	5	1	19	41	571	115	0	22	0	2	0	5	15	159			
17:30 to 18:30	194	6	35	3	2	9	15	12	276	359	10	106	10	4	1	23	57	570	117	1	19	0	2	0	7	11	157			
17:45 to 18:45	220	4	33	2	2	10	13	10	294	356	8	106	11	0	0	17	61	559	139	1	16	2	2	0	7	8	175			
18:00 to 19:00	201	6	29	2	2	10	13	7	270	352	5	85	9	0	0	16	66	533	131	2	12	2	1	1	6	8	163			



SKY HIGH LTD - THE TRAFFIC SURVEY COMPANY

Job :
Client : Peter Bretts Associates
Location : Ilderton Road/Surrey Canal Road
Day : Thurs 09th July 2009
Weather : Fine
Peak Hour AM : 9:00 AM to 10:00 AM
Peak Hour PM : 4:00 PM to 5:00 PM

Choose Time Period

7:00 to 8:00

- = Total number by direction
- = Total number of inbound and outbound traffic flows

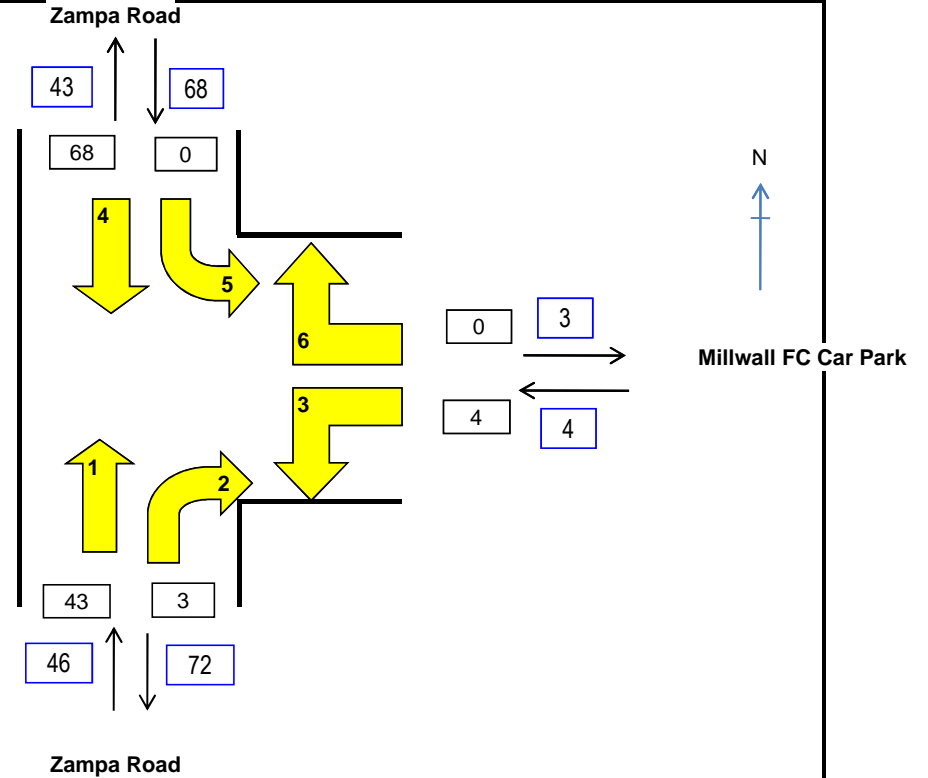



SKY HIGH LTD - THE TRAFFIC SURVEY COMPANY

AM 15 Minute Data Summary

Job :
Client : Peter Bretts Associates
Location : Ilderton Road/Stockholm Road
Day : Thurs 09th July 2009
Weather : Fine
Peak Hour AM 7:45 AM to 8:45 AM

Vehicle Class Summary

Cats	Taxi	LGV	OGV1	OGV2	PSV	MC	Cycles
58.5%	1.0%	22.1%	4.5%	4.2%	1.7%	2.8%	5.2%

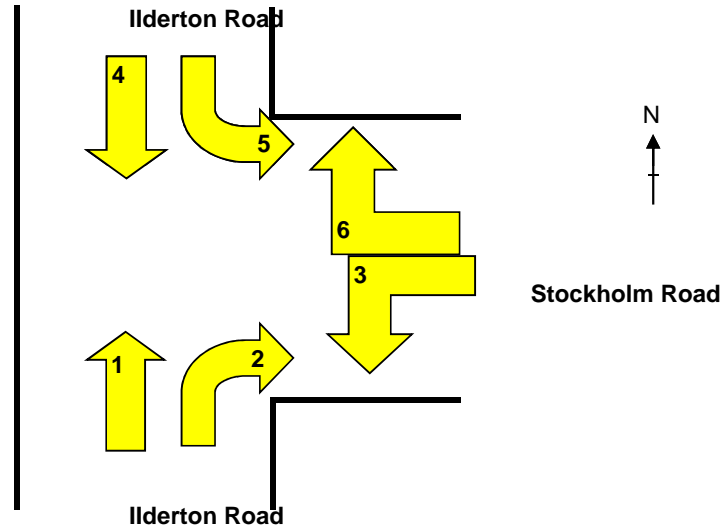

Time Period	Direction 1									Direction 2									Direction 3								
	Cars	Taxi	LGV	OGV1	OGV2	PSV	MC	Cycles	Total	Cars	Taxi	LGV	OGV1	OGV2	PSV	MC	Cycles	Total	Cars	Taxi	LGV	OGV1	OGV2	PSV	MC	Cycles	Total
07:00 to 07:15	119	1	51	6	15	2	8	3	205	0	0	0	0	0	0	0	0	0	0	0	0	0	0	0	0	0	0
07:15 to 07:30	126	0	46	12	4	3	6	9	206	0	0	0	0	0	0	0	0	0	0	0	0	0	0	0	0	0	
07:30 to 07:45	120	1	65	6	9	2	4	10	217	0	0	0	0	0	0	0	0	0	0	0	2	0	0	0	0	2	4
07:45 to 08:00	128	2	45	7	7	3	2	12	206	0	0	0	0	0	0	0	0	0	0	0	2	0	0	0	0	1	3
08:00 to 08:15	108	2	34	5	10	2	6	13	180	0	0	0	0	0	0	0	0	0	1	0	1	0	0	0	0	0	2
08:15 to 08:30	124	1	31	2	4	1	9	29	201	0	0	0	0	0	0	0	0	0	1	0	2	0	0	0	0	1	4
08:30 to 08:45	144	1	44	4	5	2	14	20	234	0	0	0	0	0	0	0	0	0	0	0	0	0	0	0	0	0	
08:45 to 09:00	80	2	26	3	7	2	7	14	141	0	0	0	0	0	0	0	0	0	0	0	0	0	0	0	0	0	
09:00 to 09:15	108	1	36	7	6	2	7	7	174	0	0	0	0	0	0	0	0	0	0	0	0	0	0	0	0	0	
09:15 to 09:30	109	2	39	1	8	1	4	14	178	0	0	0	0	0	0	0	0	0	1	1	2	0	0	0	0	4	
09:30 to 09:45	105	1	38	5	19	2	1	8	179	0	0	0	0	0	0	0	0	0	0	1	0	0	0	2	0	3	
09:45 to 10:00	84	5	34	7	6	3	9	6	154	0	0	0	0	0	0	0	0	0	0	0	2	0	2	0	0	4	
Survey Total	1355	19	489	65	100	25	77	145	2275	0	0	0	0	0	0	0	0	0	3	2	11	0	2	2	0	4	24

Time Period	Direction 4									Direction 5									Direction 6								
	Cars	Taxi	LGV	OGV1	OGV2	PSV	MC	Cycles	Total	Cars	Taxi	LGV	OGV1	OGV2	PSV	MC	Cycles	Total	Cars	Taxi	LGV	OGV1	OGV2	PSV	MC	Cycles	Total
07:00 to 07:15	21	1	6	4	1	1	1	0	35	0	0	0	0	0	0	0	0	0	0	0	0	0	0	0	0	0	0
07:15 to 07:30	43	1	12	7	5	1	1	4	74	1	0	2	2	1	0	0	0	6	0	0	0	0	0	0	0	0	0
07:30 to 07:45	50	1	24	7	5	2	3	3	95	2	0	0	0	0	0	0	0	2	0	0	0	0	0	0	0	2	2
07:45 to 08:00	52	0	21	7	5	2	1	3	91	2	0	0	0	0	0	0	0	2	1	0	0	0	0	0	0	1	2
08:00 to 08:15	50	0	16	8	0	1	1	0	76	0	0	0	0	0	0	0	0	0	0	0	0	0	1	0	0	0	1
08:15 to 08:30	50	0	11	2	2	4	3	1	73	0	0	1	0	2	0	0	0	3	1	0	0	0	0	0	0	1	2
08:30 to 08:45	58	2	28	4	3	2	1	1	99	0	0	0	0	0	0	0	0	0	0	0	0	0	0	0	0	0	0
08:45 to 09:00	69	1	29	3	2	1	1	1	107	0	0	0	0	0	0	0	2	2	0	0	0	0	0	0	0	0	0
09:00 to 09:15	64	1	29	13	1	5	1	1	115	0	0	1	0	0	0	0	0	1	0	0	0	0	0	0	0	0	0
09:15 to 09:30	60	1	27	11	4	5	0	2	110	0	0	1	2	0	1	0	0	4	0	0	0	0	0	0	0	0	0
09:30 to 09:45	55	3	24	5	1	4	2	0	94	0	0	1	0	0	2	0	0	3	0	0	0	0	0	0	0	0	0
09:45 to 10:00	8	0	1	5	4	0	0	2	20	0	0	1	5	0	0	0	0	6	0	0	0	0	0	0	0	0	0
Survey Total	580	11	228	76	33	28	15	18	989	5	0	7	9	3	3	0	2	29	2	0	0	0	1	0	0	4	7

PM 15 Minute Data Summary

Job :
Client : Peter Bretts Associates
Location : Ilderton Road/Stockholm Road
Day : Thurs 09th July 2009
Weather : Fine
Peak Hour PM 5:45 PM to 6:45 PM

Vehicle Class Summary							
Cars	MC	LGV	OGV	OGV	PSV	MC	Cycle
68.7%	1.4%	18.3%	2.2%	0.3%	1.1%	3.3%	4.6%

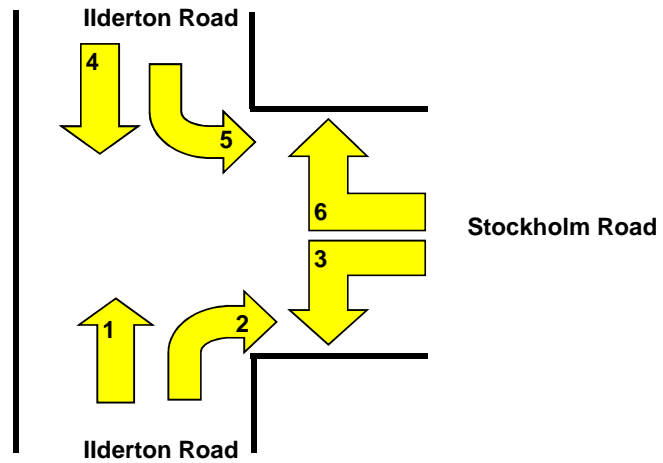

Time Period	Direction 1									Direction 2									Direction 3								
	Cars	Taxi	LGV	OGV1	OGV2	PSV	MC	Cycles	Total	Cars	Taxi	LGV	OGV1	OGV2	PSV	MC	Cycles	Total	Cars	Taxi	LGV	OGV1	OGV2	PSV	MC	Cycles	Total
16:00 to 16:15	65	2	22	3	1	2	2	1	98	3	0	1	0	0	0	0	0	4	2	0	0	0	0	0	0	0	2
16:15 to 16:30	65	0	13	1	2	0	3	1	85	3	0	0	0	0	0	0	0	3	0	0	0	0	0	0	0	0	0
16:30 to 16:45	59	1	12	3	1	5	1	2	84	3	0	1	0	0	0	0	0	4	0	0	0	0	0	0	0	0	0
16:45 to 17:00	54	2	12	4	3	3	2	4	84	0	0	0	0	0	1	0	0	1	0	0	0	0	0	0	0	0	0
17:00 to 17:15	58	2	9	1	0	1	3	5	79	3	0	0	0	0	0	0	0	3	0	0	0	0	0	0	0	0	0
17:15 to 17:30	70	1	12	2	0	3	5	6	99	2	0	0	0	0	0	0	0	2	0	0	0	0	0	0	0	0	0
17:30 to 17:45	72	3	13	2	0	1	6	8	105	3	0	0	0	0	0	0	0	3	1	0	0	0	0	0	0	1	2
17:45 to 18:00	75	0	12	0	2	2	4	4	99	1	0	0	0	0	0	0	0	1	0	0	0	0	0	0	0	0	0
18:00 to 18:15	64	1	10	1	0	0	1	7	84	0	0	1	0	0	0	1	0	2	0	0	0	0	0	0	0	0	0
18:15 to 18:30	75	1	5	0	0	2	5	2	90	2	0	0	0	0	0	1	0	3	0	0	0	0	0	0	0	0	0
18:30 to 18:45	100	2	14	2	0	1	5	5	129	0	0	0	0	0	0	0	0	0	0	0	0	0	0	0	0	0	0
18:45 to 19:00	87	1	8	2	2	2	1	3	106	1	0	0	0	0	0	0	0	1	1	0	1	0	0	0	0	0	2
Survey Total	844	16	142	21	11	22	38	48	1142	21	0	3	0	0	1	2	0	27	4	0	1	0	0	0	0	1	6

AM Hourly Summary

Job :
Client : Peter Bretts Associates
Location : Ilderton Road/Stockholm Road
Day : Thurs 09th July 2009
Weather : Fine
Peak Hour AM 7:45 AM to 8:45 AM
Peak Hour PM 5:45 PM to 5:00PM

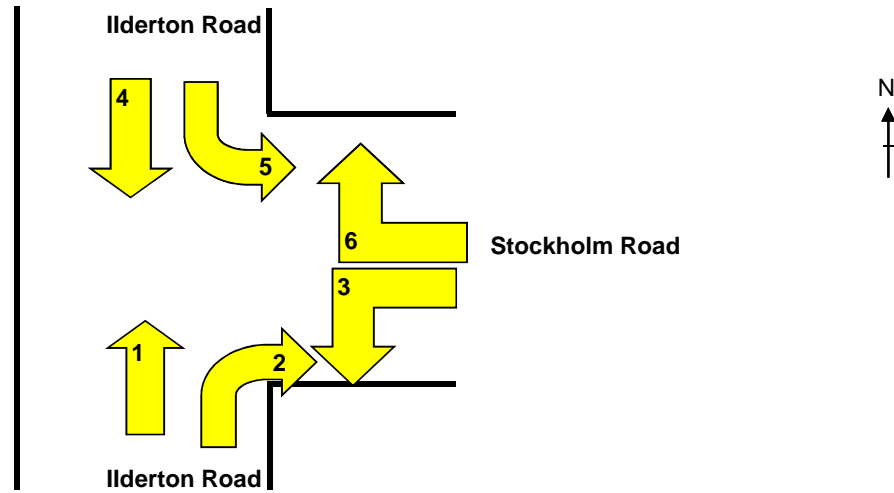

Time Period			Direction 1								Direction 2								Direction 3											
			Cars	Taxi	LGV	OGV1	OGV2	PSV	MC	Cycles	Total	Cars	Taxi	LGV	OGV1	OGV2	PSV	MC	Cycles	Total	Cars	Taxi	LGV	OGV1	OGV2	PSV	MC	Cycles	Total	
07:00	to	08:00	493	4	207	31	35	10	20	34	834	0	0	0	0	0	0	0	0	0	0	0	4	0	0	0	0	0	3	7
07:15	to	08:15	482	5	190	30	30	10	18	44	809	0	0	0	0	0	0	0	0	0	1	0	5	0	0	0	0	0	3	9
07:30	to	08:30	480	6	175	20	30	8	21	64	804	0	0	0	0	0	0	0	0	0	2	0	7	0	0	0	0	0	4	13
07:45	to	08:45	504	6	154	18	26	8	31	74	821	0	0	0	0	0	0	0	0	0	2	0	5	0	0	0	0	0	2	9
08:00	to	09:00	456	6	135	14	26	7	36	76	756	0	0	0	0	0	0	0	0	0	2	0	3	0	0	0	0	0	1	6
08:15	to	09:15	456	5	137	16	22	7	37	70	750	0	0	0	0	0	0	0	0	0	1	0	2	0	0	0	0	0	1	4
08:30	to	09:30	441	6	145	15	26	7	32	55	727	0	0	0	0	0	0	0	0	0	1	1	2	0	0	0	0	0	0	4
08:45	to	09:45	402	6	139	16	40	7	19	43	672	0	0	0	0	0	0	0	0	0	1	2	2	0	0	2	0	0	0	7
09:00	to	10:00	406	9	147	20	39	8	21	35	685	0	0	0	0	0	0	0	0	0	1	2	4	0	2	2	0	0	0	11

PM Hourly Summary

Time Period			Direction 1								Direction 2								Direction 3										
			Cars	Taxi	LGV	OGV1	OGV2	PSV	MC	Cycles	Total	Cars	Taxi	LGV	OGV1	OGV2	PSV	MC	Cycles	Total	Cars	Taxi	LGV	OGV1	OGV2	PSV	MC	Cycles	Total
16:00	to	17:00	243	5	59	11	7	10	8	8	351	9	0	2	0	0	1	0	0	12	2	0	0	0	0	0	0	0	2
16:15	to	17:15	236	5	46	9	6	9	9	12	332	9	0	1	0	0	1	0	0	11	0	0	0	0	0	0	0	0	0
16:30	to	17:30	241	6	45	10	4	12	11	17	346	8	0	1	0	0	1	0	0	10	0	0	0	0	0	0	0	0	0
16:45	to	17:45	254	8	46	9	3	8	16	23	367	8	0	0	0	0	1	0	0	9	1	0	0	0	0	0	0	1	2
17:00	to	18:00	275	6	46	5	2	7	18	23	382	9	0	0	0	0	0	0	0	9	1	0	0	0	0	0	0	1	2
17:15	to	18:15	281	5	47	5	2	6	16	25	387	6	0	1	0	0	0	1	0	8	1	0	0	0	0	0	0	1	2
17:30	to	18:30	286	5	40	3	2	5	16	21	378	6	0	1	0	0	0	2	0	9	1	0	0	0	0	0	0	1	2
17:45	to	18:45	314	4	41	3	2	5	15	18	402	3	0	1	0	0	0	2	0	6	0	0	0	0	0	0	0	0	0
18:00	to	19:00	326	5	37	5	2	5	12	17	409	3	0	1	0	0	0	2	0	6	1	0	1	0	0	0	0	0	2





SKY HIGH LTD - THE TRAFFIC SURVEY COMPANY

Job :
Client : Peter Bretts Associates
Location : Ilderton Road/Stockholm Road
Day : Thurs 09th July 2009
Weather : Fine
Peak Hour AM 7:45 AM to 8:45 AM
Peak Hour PM 5:45 PM to 6:45 PM

Choose Time Period

7:00 to 8:00 ▼

 = Total number by direction

 = Total number of inbound and outbound traffic flows

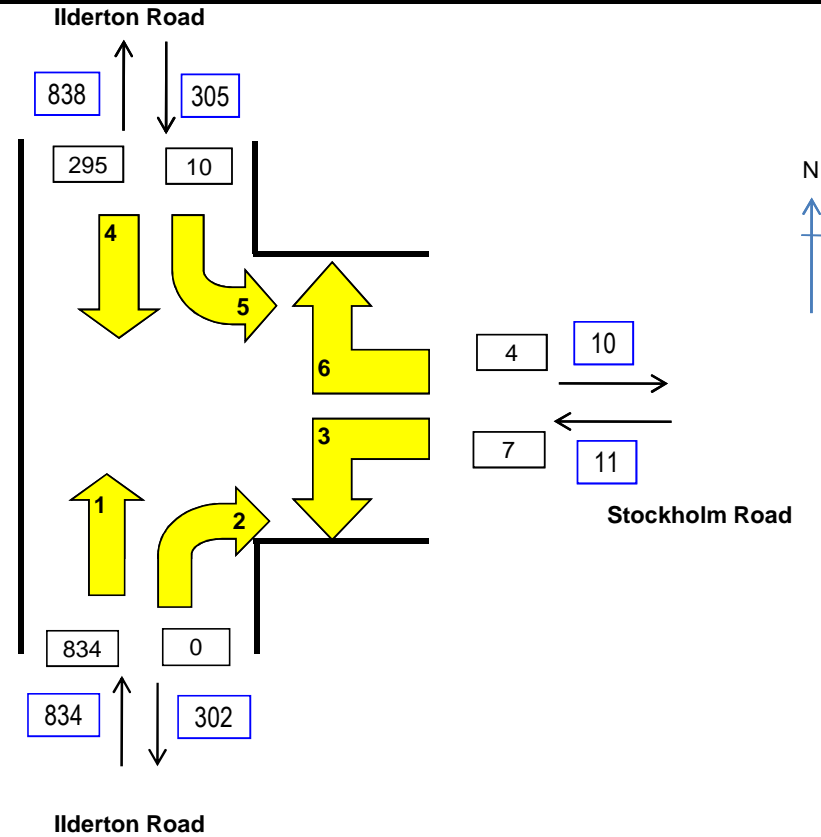



SKY HIGH LTD - THE TRAFFIC SURVEY COMPANY

15 Minute Data Summary			
Job no	:		
Client	:	Peter Bretts Associates	
Location	:	Ilderton Road/Penarth St/ Rellins St	
Date	:	Thurs 09th July 2009	
Weather	:	Fine	
Peak Hour AM	9:00 AM	to	10:00 AM
Peak Hour PM	5:15 PM		6:15 PM

Penarth Street

Vehicle Class Summary							
Cars	Taxi	LGV	OGV1	OGV2	PSV	MC	Cycles
74.5%	1.9%	10.7%	3.9%	3.8%	1.3%	2.4%	1.5%

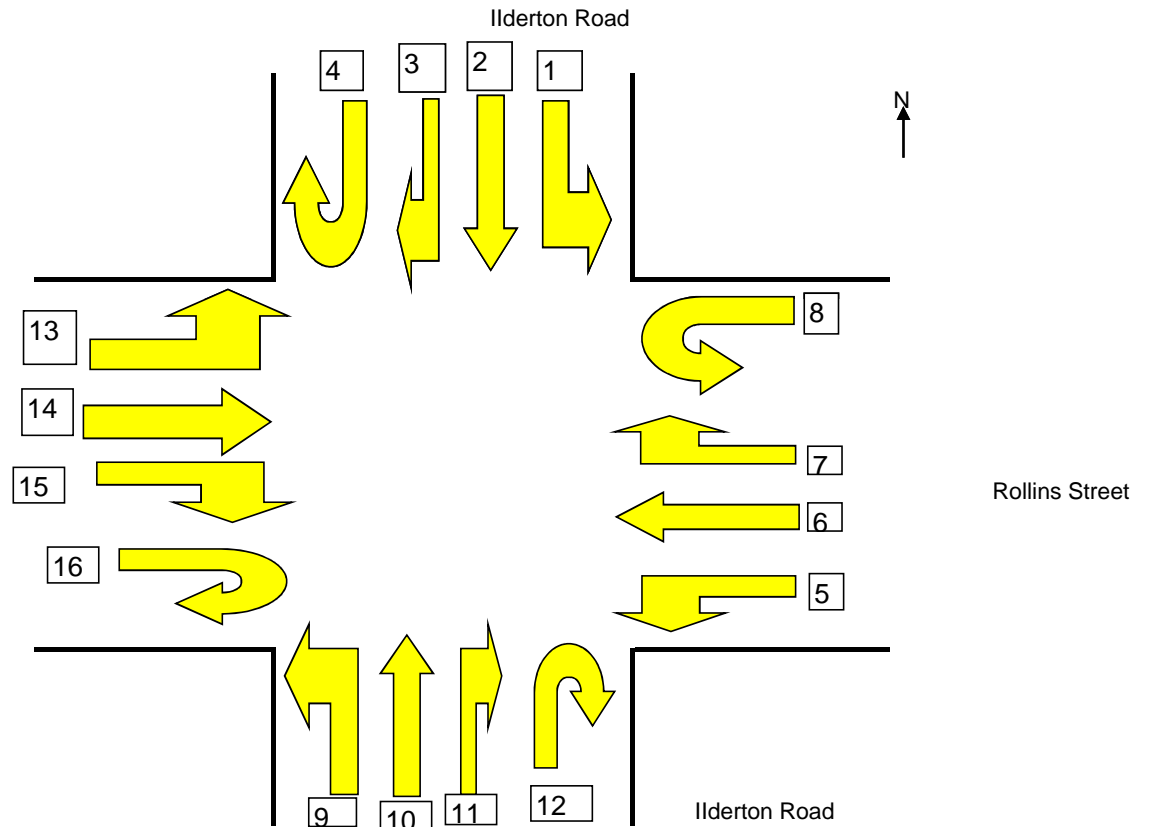

Time Period	Direction 1									Direction 2									Direction 3									Direction 4	
	Cars	Taxi	LGV	OGV1	OGV2	PSV	MC	Cycles	Total	Cars	Taxi	LGV	OGV1	OGV2	PSV	MC	Cycles	Total	Cars	Taxi	LGV	OGV1	OGV2	PSV	MC	Cycles	Total	Cars	Taxi
07:00 to 07:15	2	0	0	0	1	0	0	0	3	36	0	3	3	2	2	0	0	46	0	0	3	7	2	0	1	0	13		
07:15 to 07:30	2	0	0	0	3	0	0	1	6	41	0	5	4	8	1	1	2	62	5	0	1	2	0	0	0	0	8		
07:30 to 07:45	1	0	0	1	0	0	0	0	2	48	0	6	6	2	2	0	0	64	0	1	0	0	0	0	0	0	1		
07:45 to 08:00	2	0	0	0	0	0	0	0	2	37	0	9	8	7	2	2	0	65	3	0	2	0	1	0	0	0	6		
08:00 to 08:15	2	0	0	0	0	0	0	1	3	0	3	6	4	5	1	1	0	20	4	1	1	1	1	0	0	0	8		
08:15 to 08:30	3	0	1	0	0	0	0	1	5	31	0	3	2	2	1	1	0	40	1	0	0	0	0	0	0	0	1		
08:30 to 08:45	1	0	0	0	0	0	0	1	2	49	2	2	6	10	2	3	0	74	3	0	0	1	0	0	0	1	5		
08:45 to 09:00	1	0	0	0	3	0	0	0	4	56	1	3	2	1	0	0	0	63	3	0	0	1	0	0	0	1	5		
09:00 to 09:15	1	0	0	0	0	0	0	0	1	43	1	8	1	8	2	0	0	63	1	0	0	2	0	0	0	0	3		
09:15 to 09:30	1	0	0	1	2	0	0	0	4	33	1	2	3	5	2	0	0	46	2	3	0	0	0	0	0	0	5		
09:30 to 09:45	2	0	0	1	1	0	0	0	4	56	2	6	7	17	2	1	0	91	0	0	0	0	0	0	0	0	0		
09:45 to 10:00	0	0	0	1	0	0	0	0	1	48	5	10	7	14	3	2	2	91	1	0	3	2	1	0	0	0	7		
16:00 to 16:15	7	0	0	0	0	0	0	0	7	76	0	8	0	2	0	3	1	90	4	0	1	0	0	0	0	1	6		
16:15 to 16:30	1	0	1	0	0	0	0	0	2	74	5	5	3	3	3	3	2	98	0	1	1	0	1	0	0	0	3		
16:30 to 16:45	3	0	0	0	0	0	0	0	3	77	0	2	5	1	2	3	0	90	5	0	1	1	0	0	0	0	7		
16:45 to 17:00	2	0	1	0	0	0	0	0	3	83	0	4	5	2	1	4	1	100	3	0	1	0	0	0	0	0	4		
17:00 to 17:15	3	0	0	0	0	0	0	0	3	89	2	5	3	1	0	6	2	108	1	0	0	0	0	0	0	0	1		
17:15 to 17:30	0	0	0	0	0	0	0	0	0	92	0	2	2	2	2	7	1	108	1	1	1	0	0	0	0	0	3		
17:30 to 17:45	3	0	0	0	0	0	0	0	3	92	1	7	1	0	3	4	5	113	2	0	0	0	0	0	0	0	2		
17:45 to 18:00	0	0	0	0	0	0	1	0	1	97	1	3	0	1	0	3	3	108	2	0	1	0	1	0	0	0	4		
18:00 to 18:15	1	0	0	0	0	0	0	0	1	100	1	1	4	3	2	5	3	119	7	0	0	0	0	0	1	0	8		
18:15 to 18:30	3	0	0	0	0	0	0	0	3	85	0	7	0	0	0	8	3	103	4	3	0	1	0	0	0	0	8		
18:30 to 18:45	1	0	0	0	0	0	0	0	1	114	0	3	0	1	2	1	3	124	4	0	0	0	0	0	0	0	4		
18:45 to 19:00	1	0	0	0	0	0	0	0	1	79	4	1	0	0	1	4	4	93	3	1	0	0	0	0	0	0	4		
Survey Total	43	0	3	4	10	0	1	4	65	1536	29	111	76	97	36	62	32	1979	59	11	16	18	7	0	2	3	116	0	0

Time Period	Direction 5									Direction 6									Direction 7									Direction 8	
	Cars	Taxi	LGV	OGV1	OGV2	PSV	MC	Cycles	Total	Cars	Taxi	LGV	OGV1	OGV2	PSV	MC	Cycles	Total	Cars	Taxi	LGV	OGV1	OGV2	PSV	MC	Cycles	Total	Cars	Taxi
07:00 to 07:15	6	0	4	2	1	0	0	0	13	0	0	0	0	0	0	0	0	0	1	0	0	3	0	0	0	0	4		
07:15 to 07:30	2	0	2	1	3	0	0	0	8	1	0	1	1	2	0	0	0	5	2	0	0	2	0	0	0	1	5		
07:30 to 07:45	0	0	6	8	2	0	0	0	16	2	0	3	0	0	0	0	5	4	0	0	0	0	0	0	0	4			
07:45 to 08:00	3	0	1	0	0	0	0	0	4	2	0	1	3	0	0	0	6	5	0	0	0	0	0	0	0	5			
08:00 to 08:15	1	0	0	0	0	0	0	0	1	1	0	0	0	0	0	1	2	7	0	0	0	0	0	0	0	7			
08:15 to 08:30	5	0	0	0	0	0	0	0	5	5	0	0	0	0	0	0	5	11	0	0	0	0	0	0	0	11			
08:30 to 08:45	3	0	0	0	0	0	0	0	3	0	0	0	0	1	0	0	1	9	0	0	0	0	0	0	0	9			
08:45 to 09:00	3	0	0	0	2	0	0	0	5	1	0	0	0	0	0	0	1	8	0	0	0	0	0	0	0	8			
09:00 to 09:15	1	0	0	0	0	0	0	0	1	2	0	2	0	0	0	0	4	7	0	1	1	0	0	0	0	9			
09:15 to 09:30	0	0	2	0	0	0	0	0	2	0	0	0	0	0	0	1	1	6	0	1	1	1	0	0	1	10			
09:30 to 09:45	0	0	1	3	2	0	0	0	6	2	0	0	0	0	0	0	2	4	0	0	0	0	0	0	0	4			
09:45 to 10:00	1	0	1	0	1	0	0	0	3	2	0	0	0	2	0	0	4	9	0	4	3	2	0	0	0	18			
16:00 to 16:15	2	0	1	0	0	0	0	0	3	0	0	2	0	0	0	0	2	8	0	2	0	0	0	0	0	10			
16:15 to 16:30	2	0	1	0	0	0	1	0	4	0	0	0	0	0	0	0	0	11	0	0	0	0	0	0	0	11			
16:30 to 16:45	7	0	3	0	0	0	0	0	10	1	0	0	0	0	0	0	1	9	0	0	0	0	0	0	0	9			
16:45 to 17:00	6	3	0	0	0	0	0	0	9	2	0	1	0	0	0	1	4	10	0	0	2	0	0	0	0	12			
17:00 to 17:15	1	0	0	0	0	0	1	0	2	0	0	0	0	0	0	0	0	11	0	0	0	0	0	0	0	11			
17:15 to 17:30	5	0	0	0	0	0	3	0	8	2	0	1	0	0	0	2	5	12	0	1	0	0	0	0	0	13			
17:30 to 17:45	4	0	0	2	0	0	0	0	6	1	0	0	0	0	0	0	1	0	0	0	0	0	0	0	0	0			
17:45 to 18:00	2	0	0	2	1	0	0	0	5	0	0	0	0	0	0	0	0	6	0	0	0	0	0	0	1	7			
18:00 to 18:15	3	0	1	0	0	0	0	0	4	0	0	0	0	0	0	0	0	6	0	0	0	0	0	1	0	7			
18:15 to 18:30	3	0	0	0	0	0	0	0	3	0	0	0	0	0	0	0	0	1	0	0	0	0	0	0	0	1			
18:30 to 18:45	4	0	2	0	0	0	0	0	6	0	2	0	0	0	0	0	2	2	0	0	0	0	0	0	0	2			
18:45 to 19:00	3	0	0	0	0	0	0	0	3	1	0	0	0	0	0	0	1	6	0	0	0	0	0	0	0	6			
Survey Total	67	3	25	18	12	0	5	0	130	25	2	11	4	5	0	3	2	52	155	0	9	12	3	0	1	3	183	0	0

Time Period	Direction 9									Direction 10									Direction 11									Direction 1	
	Cars	Taxi	LGV	OGV1	OGV2	PSV	MC	Cycles	Total	Cars	Taxi	LGV	OGV1	OGV2	PSV	MC	Cycles	Total	Cars	Taxi	LGV	OGV1	OGV2	PSV	MC	Cycles	Total	Cars	Taxi
07:00 to 07:15	2	0	1	1	0	0	0	0	4	79	2	14	3	4	1	3	1	107	2	0	3	0	0	0	0	0	5		
07:15 to 07:30	0	1	2	0	0	0	0	0	3	68	1	3	3	5	2	1	2	85	3	0	3	2	1	0	0	0	9		
07:30 to 07:45	1	0	2	0	0	0	0	0	3	72	2	9	6	4	1	2	2	98	3	0	0	0	0	0	0	6	9		
07:45 to 08:00	0	0	1	1	0	0	0	0	2	79	2	16	1	9	3	4	1	115	4	0	0	0	0	0	0	0	4		
08:00 to 08:15	4	0	0	0	0	0	0	0	4	86	0	1	0	5	1	3	4	100	4	0	1	1	0	0	0	0	6		
08:15 to 08:30	3	0	1	0	0	0	0	0	4	119	2	16	0	4	1	3	5	150	2	0	0	0	0	0	0	0	2		
08:30 to 08:45	2	0	0	0	0	0	0	1	3	69	13	13	0	1	2	4	4	106	0	0	0	0	0	0	0	0	0		
08:45 to 09:00	2	0	1	0	0	0	0	0	3	77	4	19	8	2	1	3	2	116	0	0	1	0	0	0	0	2	3		
09:00 to 09:15	1	0	0	0	0	0	0	0	1	89	0	13	2	6	1	0	1	112	1	0	1	0	1	0	0	0	3		
09:15 to 09:30	4	0	3	0	0	0	0	0	7	68	1	16	0	2	1	1	1	90	0	0	1	1	0	0	0	0	2		
09:30 to 09:45	4	0	5	1	0	0	0	0	10	89	3	19	3	6	2	1	2	125	0	0	0	0	0	0	0	0	0		
09:45 to 10:00	2	0	3	0	0	0	0	0	5	99	3	18	0	9	1	5	2	137	0	0	1	2	1	0	0	0	4		
16:00 to 16:15	0	0	0	0	0	0	0	0	0	83	0	15	5	2	2	1	0	108	5	0	2	2	0	0	0	0	9		
16:15 to 16:30	2	1	0	0	0	0	0	0	3	80	1	21	2	2	3	0	1	110	3	0	1	0	0	0	0	0	4		
16:30 to 16:45	5	0	1	0	0	0	0	0	6	84	1	21	5	2	3	3	0	119	0	0	3	0	0	0	0	0	3		
16:45 to 17:00	0	0	0	2	0	0	0	0	2	89	0	10	2	3	2	1	0	107	5	0	0	0	0	0	0	0	5		
17:00 to 17:15	0	0	0	0	0	0	0	0	0	93	1	20	3	2	2	3	0	124	3	0	0	2	0	0	1	0	6		
17:15 to 17:30	0	0	2	1	0	0	0	0	3	66	1	17	2	4	3	0	0	93	3	0	1	0	0	0	1	0	5		
17:30 to 17:45	3	0	0	0	0	0	0	0	3	83	1	14	1	0	0	2	0	101	3	0	0	0	0	0	0	0	3		
17:45 to 18:00	2	0	1	0	0	0	0	0	3	82	0	15	2	0	2	1	0	102	7	0	1	0	0	0	0	0	8		
18:00 to 18:15	2	0	2	0	0	0	0	0	4	92	0	14	0	1	1	1	0	109	1	0	0	0	0	0	0	0	1		
18:15 to 18:30	0	0	0	1	0	0	0	0	1	94	1	14	1	0	1	2	0	113	1	0	0	0	0	0	0	0	1		
18:30 to 18:45	1	2	0	0	0	0	0	0	3	84	1	7	0	1	1	3	0	97	3	0	1	0	0	0	0	0	4		
18:45 to 19:00	0	1	0	0	0	0	0	0	1	91	0	14	1	1	1	2	1	111	1	0	0	0	0	0	0	0	1		
Survey Total	40	5	25	7	0	0	0	1	78	2015	40	339	50	75	38	49	29	2635	54	0	20	10	3	0	2	8	97	0	0

Time Period	Direction 13									Direction 14									Direction 15									Direction 1	
	Cars	Taxi	LGV	OGV1	OGV2	PSV	MC	Cycles	Total	Cars	Taxi	LGV	OGV1	OGV2	PSV	MC	Cycles	Total	Cars	Taxi	LGV	OGV1	OGV2	PSV	MC	Cycles	Total	Cars	Taxi
07:00 to 07:15	1	0	0	3	0	0	1	0	5	0	0	0	1	0	0	0	0	1	1	0	0	0	0	0	0	1			
07:15 to 07:30	1	0	2	0	0	0	0	0	3	0	0	0	0	0	0	0	0	0	0	0	1	0	0	0	0	1			
07:30 to 07:45	3	0	2	0	0	0	0	0	5	0	0	0	0	0	0	0	0	0	1	0	0	1	0	0	0	2			
07:45 to 08:00	4	0	0	0	0	0	0	0	4	0	0	0	0	0	0	0	0	0	0	0	1	0	0	0	0	1			
08:00 to 08:15	8	3	1	0	0	0	0	0	12	1	0	0	0	0	0	0	0	1	0	0	3	0	0	0	0	3			
08:15 to 08:30	7	0	0	1	0	0	0	0	8	0	0	0	0	0	0	0	0	0	0	0	0	0	0	0	0	0			
08:30 to 08:45	9	0	1	0	0	0	0	0	10	0	0	0	0	0	0	0	0	0	1	0	0	1	1	0	0	3			
08:45 to 09:00	8	2	3	0	0	0	2	1	16	1	0	0	0	0	0	0	0	1	1	0	1	0	0	0	0	2			
09:00 to 09:15	10	0	1	1	0	0	0	0	12	0	0	0	0	0	0	0	0	0	0	0	0	1	0	0	0	1			
09:15 to 09:30	9	1	0	1	0	0	0	0	11	0	0	1	0	0	0	0	0	1	1	0	0	0	0	0	0	1			
09:30 to 09:45	8	1	0	0	0	0	0	0	9	0	0	0	0	0	0	0	0	0	3	0	2	0	0	0	0	5			
09:45 to 10:00	5	1	2	0	0	0	0	0	8	0	0	0	0	0	0	0	0	0	0	0	2	0	0	0	0	2			
16:00 to 16:15	8	0	0	1	0	0	0	0	9	0	0	0	0	0	0	0	0	0	2	1	0	0	0	0	0	3			
16:15 to 16:30	6	0	3	1	0	0	1	0	11	0	0	0	0	0	0	0	0	0	2	0	1	0	0	0	0	3			
16:30 to 16:45	9	0	1	1	0	0	0	0	11	0	0	0	0	0	0	0	0	0	2	0	1	1	0	0	1	5			
16:45 to 17:00	8	1	2	0	0	0	0	0	11	2	0	0	0	0	0	0	0	2	3	0	2	1	0	0	0	6			
17:00 to 17:15	11	0	2	2	0	0	0	0	15	0	0	0	0	0	0	0	0	0	1	0	1	0	0	0	0	3			
17:15 to 17:30	8	0	2	0	0	0	0	0	10	0	0	0	0	0	0	0	0	0	0	1	2	1	0	0	0	7			
17:30 to 17:45	9	2	1	0	0	0	1	0	13	0	0	0	1	0	0	0	0	1	2	0	1	0	0	0	0	3			
17:45 to 18:00	8	1	3	1	0	0	0	0	13	1	0	0	0	0	0	0	0	1	1	0	0	0	0	0	0	1			
18:00 to 18:15	4	0	1	0	0	0	3	0	8	0	0	0	0	0	0	0	0	0	1	0	0	0	0	0	0	1			
18:15 to 18:30	8	0	1	0	0	0	0	1	10	0	0	0	0	0	0	0	0	0	2	0	1	0	0	0	0	3			
18:30 to 18:45	5	2	3	1	0	0	0	0	11	0	0	0	0	0	0	0	0	0	1	0	1	0	0	0	0	2			
18:45 to 19:00	3	2	1	2	0	0	1	0	9	2	0	0	0	0	0	0	0	2	2	0	0	0	0	0	0	2			
Survey Total	160	16	32	15	0	0	9	2	234	7	0	1	2	0	0	0	0	10	27	2	18	7	2	0	1	4	61	0	0

Hourly Summary

Job no :
Client : Peter Bretts Associates
Location : Ilderton Road/Penarth St/ Rellins St
Weather : Thurs 09th July 2009
Peak Hour AM : Fine to 12:00 AM

Penarth Street

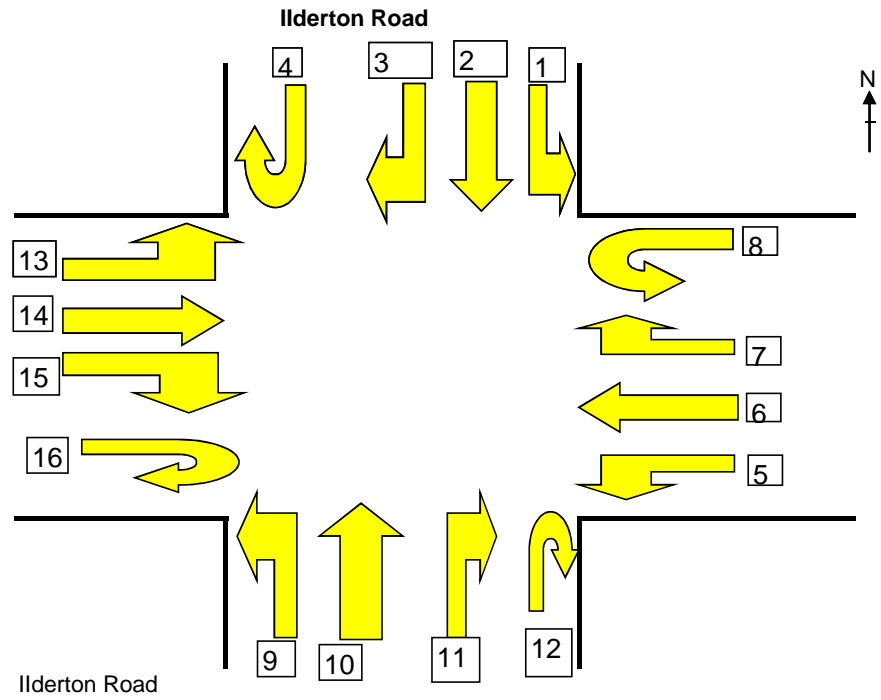

		Direction 1									Direction 2									Direction 3									Direction 4	
Time Period		Cars	Taxi	LGV	OGV1	OGV2	PSV	MC	Cycles	Total	Cars	Taxi	LGV	OGV1	OGV2	PSV	MC	Cycles	Total	Cars	Taxi	LGV	OGV1	OGV2	PSV	MC	Cycles	Total	Cars	Taxi
07:00 to 08:00		7	0	0	1	4	0	0	1	13	162	0	23	21	19	7	3	2	237	8	1	6	9	3	0	1	0	28	0	0
07:15 to 08:15		7	0	0	1	3	0	0	2	13	126	3	26	22	22	6	4	2	211	12	2	4	3	2	0	0	0	23	0	0
07:30 to 08:30		8	0	1	1	0	0	0	2	12	116	3	24	20	16	6	4	0	189	8	2	3	1	2	0	0	0	16	0	0
07:45 to 08:45		8	0	1	0	0	0	0	3	12	117	5	20	20	24	6	7	0	199	11	1	3	2	2	0	0	1	20	0	0
08:00 to 09:00		7	0	1	0	3	0	0	3	14	136	6	14	14	18	4	5	0	197	11	1	1	3	1	0	0	2	19	0	0
08:15 to 09:15		6	0	1	0	3	0	0	2	12	179	4	16	11	21	5	4	0	240	8	0	0	4	0	0	0	2	14	0	0
08:30 to 09:30		4	0	0	1	5	0	0	1	11	181	5	15	12	24	6	3	0	246	9	3	0	4	0	0	0	2	18	0	0
08:45 to 09:45		5	0	0	2	6	0	0	0	13	188	5	19	13	31	6	1	0	263	6	3	0	3	0	0	0	1	13	0	0
09:00 to 10:00		4	0	0	3	3	0	0	0	10	180	9	26	18	44	9	3	2	291	4	3	3	4	1	0	0	0	15	0	0
16:00 to 17:00		13	0	2	0	0	0	0	0	15	310	5	19	13	8	6	13	4	378	12	1	4	1	1	0	0	1	20	0	0
16:15 to 17:15		9	0	2	0	0	0	0	0	11	323	7	16	16	7	6	16	5	396	9	1	3	1	1	0	0	0	15	0	0
16:30 to 17:30		8	0	1	0	0	0	0	0	9	341	2	13	15	6	5	20	4	406	10	1	3	1	0	0	0	0	15	0	0
16:45 to 17:45		8	0	1	0	0	0	0	0	9	356	3	18	11	5	6	21	9	429	7	1	2	0	0	0	0	0	10	0	0
17:00 to 18:00		6	0	0	0	0	0	1	0	7	370	4	17	6	4	5	20	11	437	6	1	2	0	1	0	0	0	10	0	0
17:15 to 18:15		4	0	0	0	0	0	1	0	5	381	3	13	7	6	7	19	12	448	12	1	2	0	1	0	1	0	17	0	0
17:30 to 18:30		7	0	0	0	0	0	1	0	8	374	3	18	5	4	5	20	14	443	15	3	1	1	1	0	1	0	22	0	0
17:45 to 18:45		5	0	0	0	0	0	1	0	6	396	2	14	4	5	4	17	12	454	17	3	1	1	1	0	1	0	24	0	0
18:00 to 19:00		6	0	0	0	0	0	0	0	6	378	5	12	4	4	5	18	13	439	18	4	0	1	0	0	1	0	24	0	0

		Direction 5									Direction 6									Direction 7									Direction 8	
Time Period		Cars	Taxi	LGV	OGV1	OGV2	PSV	MC	Cycles	Total	Cars	Taxi	LGV	OGV1	OGV2	PSV	MC	Cycles	Total	Cars	Taxi	LGV	OGV1	OGV2	PSV	MC	Cycles	Total	Cars	Taxi
07:00 to	08:00	11	0	13	11	6	0	0	0	41	5	0	5	4	2	0	0	0	16	12	0	0	5	0	0	0	1	18	0	0
07:15 to	08:15	6	0	9	9	5	0	0	0	29	6	0	5	4	2	0	0	1	18	18	0	0	2	0	0	0	1	21	0	0
07:30 to	08:30	9	0	7	8	2	0	0	0	26	10	0	4	3	0	0	0	1	18	27	0	0	0	0	0	0	0	27	0	0
07:45 to	08:45	12	0	1	0	0	0	0	0	13	8	0	1	3	1	0	0	1	14	32	0	0	0	0	0	0	0	32	0	0
08:00 to	09:00	12	0	0	0	2	0	0	0	14	7	0	0	0	1	0	0	1	9	35	0	0	0	0	0	0	0	35	0	0
08:15 to	09:15	12	0	0	0	2	0	0	0	14	8	0	2	0	1	0	0	0	11	35	0	1	1	0	0	0	0	37	0	0
08:30 to	09:30	7	0	2	0	2	0	0	0	11	3	0	2	0	1	0	0	1	7	30	0	2	2	1	0	0	1	36	0	0
08:45 to	09:45	4	0	3	3	4	0	0	0	14	5	0	2	0	0	0	0	1	8	25	0	2	2	1	0	0	1	31	0	0
09:00 to	10:00	2	0	4	3	3	0	0	0	12	6	0	2	0	2	0	0	1	11	26	0	6	5	3	0	0	1	41	0	0
16:00 to	17:00	17	3	5	0	0	0	1	0	26	3	0	3	0	0	0	1	0	7	38	0	2	2	0	0	0	0	42	0	0
16:15 to	17:15	16	3	4	0	0	0	2	0	25	3	0	1	0	0	0	1	0	5	41	0	0	2	0	0	0	0	43	0	0
16:30 to	17:30	19	3	3	0	0	0	4	0	29	5	0	2	0	0	0	3	0	10	42	0	1	2	0	0	0	0	45	0	0
16:45 to	17:45	16	3	0	2	0	0	4	0	25	5	0	2	0	0	0	3	0	10	33	0	1	2	0	0	0	0	36	0	0
17:00 to	18:00	12	0	0	4	1	0	4	0	21	3	0	1	0	0	0	2	0	6	29	0	1	0	0	0	0	1	31	0	0
17:15 to	18:15	14	0	1	4	1	0	3	0	23	3	0	1	0	0	0	2	0	6	24	0	1	0	0	0	1	1	27	0	0
17:30 to	18:30	12	0	1	4	1	0	0	0	18	1	0	0	0	0	0	0	0	1	13	0	0	0	0	0	1	1	15	0	0
17:45 to	18:45	12	0	3	2	1	0	0	0	18	0	2	0	0	0	0	0	0	2	15	0	0	0	0	0	1	1	17	0	0
18:00 to	19:00	13	0	3	0	0	0	0	0	16	1	2	0	0	0	0	0	0	3	15	0	0	0	0	0	1	0	16	0	0

		Direction 9									Direction 10									Direction 11									Direction 1	
Time Period		Cars	Taxi	LGV	OGV1	OGV2	PSV	MC	Cycles	Total	Cars	Taxi	LGV	OGV1	OGV2	PSV	MC	Cycles	Total	Cars	Taxi	LGV	OGV1	OGV2	PSV	MC	Cycles	Total	Cars	Taxi
07:00 to 08:00		3	1	6	2	0	0	0	0	12	298	7	42	13	22	7	10	6	405	12	0	6	2	1	0	0	6	27	0	0
07:15 to 08:15		5	1	5	1	0	0	0	0	12	305	5	29	10	23	7	10	9	398	14	0	4	3	1	0	0	6	28	0	0
07:30 to 08:30		8	0	4	1	0	0	0	0	13	356	6	42	7	22	6	12	12	463	13	0	1	1	0	0	0	6	21	0	0
07:45 to 08:45		9	0	2	1	0	0	0	1	13	353	17	46	1	19	7	14	14	471	10	0	1	1	0	0	0	0	12	0	0
08:00 to 09:00		11	0	2	0	0	0	0	1	14	351	19	49	8	12	5	13	15	472	6	0	2	1	0	0	0	2	11	0	0
08:15 to 09:15		8	0	2	0	0	0	0	1	11	354	19	61	10	13	5	10	12	484	3	0	2	0	1	0	0	2	8	0	0
08:30 to 09:30		9	0	4	0	0	0	0	1	14	303	18	61	10	11	5	8	8	424	1	0	3	1	1	0	0	2	8	0	0
08:45 to 09:45		11	0	9	1	0	0	0	0	21	323	8	67	13	16	5	5	6	443	1	0	3	1	1	0	0	2	8	0	0
09:00 to 10:00		11	0	11	1	0	0	0	0	23	345	7	66	5	23	5	7	6	464	1	0	3	3	2	0	0	0	9	0	0
16:00 to 17:00		7	1	1	2	0	0	0	0	11	336	2	67	14	9	10	5	1	444	13	0	6	2	0	0	0	0	21	0	0
16:15 to 17:15		7	1	1	2	0	0	0	0	11	346	3	72	12	9	10	7	1	460	11	0	4	2	0	0	1	0	18	0	0
16:30 to 17:30		5	0	3	3	0	0	0	0	11	332	3	68	12	11	10	7	0	443	11	0	4	2	0	0	2	0	19	0	0
16:45 to 17:45		3	0	2	3	0	0	0	0	8	331	3	61	8	9	7	6	0	425	14	0	1	2	0	0	2	0	19	0	0
17:00 to 18:00		5	0	3	1	0	0	0	0	9	324	3	66	8	6	7	6	0	420	16	0	2	2	0	0	2	0	22	0	0
17:15 to 18:15		7	0	5	1	0	0	0	0	13	323	2	60	5	5	6	4	0	405	14	0	2	0	0	0	1	0	17	0	0
17:30 to 18:30		7	0	3	1	0	0	0	0	11	351	2	57	4	1	4	6	0	425	12	0	1	0	0	0	0	0	13	0	0
17:45 to 18:45		5	2	3	1	0	0	0	0	11	352	2	50	3	2	5	7	0	421	12	0	2	0	0	0	0	0	14	0	0
18:00 to 19:00		3	3	2	1	0	0	0	0	9	361	2	49	2	3	4	8	1	430	6	0	1	0	0	0	0	0	7	0	0

Time Period	Direction 13										Direction 14										Direction 15										Direction 1	
	Cars	Taxi	LGV	OGV1	OGV2	PSV	MC	Cycles	Total	Cars	Taxi	LGV	OGV1	OGV2	PSV	MC	Cycles	Total	Cars	Taxi	LGV	OGV1	OGV2	PSV	MC	Cycles	Total	Cars	Taxi			
07:00 to 08:00	9	0	4	3	0	0	1	0	17	0	0	0	1	0	0	0	0	1	2	0	0	3	0	0	0	0	5	0	0			
07:15 to 08:15	16	3	5	0	0	0	0	0	24	1	0	0	0	0	0	0	0	1	1	0	3	3	0	0	0	0	7	0	0			
07:30 to 08:30	22	3	3	1	0	0	0	0	29	1	0	0	0	0	0	0	0	1	1	0	3	2	0	0	0	0	6	0	0			
07:45 to 08:45	28	3	2	1	0	0	0	0	34	1	0	0	0	0	0	0	0	1	1	0	3	2	1	0	0	0	7	0	0			
08:00 to 09:00	32	5	5	1	0	0	2	1	46	2	0	0	0	0	0	0	0	2	2	0	4	1	1	0	0	0	8	0	0			
08:15 to 09:15	34	2	5	2	0	0	2	1	46	1	0	0	0	0	0	0	0	1	2	0	1	1	2	0	0	0	6	0	0			
08:30 to 09:30	36	3	5	2	0	0	2	1	49	1	0	1	0	0	0	0	0	2	3	0	1	1	2	0	0	0	7	0	0			
08:45 to 09:45	35	4	4	2	0	0	2	1	48	1	0	1	0	0	0	0	0	2	5	0	3	0	1	0	0	0	9	0	0			
09:00 to 10:00	32	3	3	2	0	0	0	0	40	0	0	1	0	0	0	0	0	1	4	0	4	0	1	0	0	0	9	0	0			
16:00 to 17:00	31	1	6	3	0	0	1	0	42	2	0	0	0	0	0	0	0	2	9	1	4	2	0	0	1	0	17	0	0			
16:15 to 17:15	34	1	8	4	0	0	1	0	48	2	0	0	0	0	0	0	0	2	8	0	5	2	0	0	1	1	17	0	0			
16:30 to 17:30	36	1	7	3	0	0	0	0	47	2	0	0	0	0	0	0	0	2	6	1	6	3	0	0	1	4	21	0	0			
16:45 to 17:45	36	3	7	2	0	0	1	0	49	2	0	0	1	0	0	0	0	3	6	1	6	2	0	0	0	4	19	0	0			
17:00 to 18:00	36	3	8	3	0	0	1	0	51	1	0	0	1	0	0	0	0	2	4	1	4	1	0	0	0	4	14	0	0			
17:15 to 18:15	29	3	7	1	0	0	4	0	44	1	0	0	1	0	0	0	0	2	4	1	3	1	0	0	0	3	12	0	0			
17:30 to 18:30	29	3	6	1	0	0	4	1	44	1	0	0	1	0	0	0	0	2	6	0	2	0	0	0	0	0	8	0	0			
17:45 to 18:45	25	3	8	2	0	0	3	1	42	1	0	0	0	0	0	0	0	1	5	0	2	0	0	0	0	0	7	0	0			
18:00 to 19:00	20	4	6	3	0	0	4	1	38	2	0	0	0	0	0	0	0	2	6	0	2	0	0	0	0	0	8	0	0			



SKY HIGH LTD - THE TRAFFIC SURVEY COMPANY

AM 15 Minute Data Summary			
Job no	:		
Client	: Peter Bretts Associates		
Location	: Ilderton Road/Penarth St/ Rollins St		
Date	: Thurs 09th July 2009		
Weather	: Fine		
Peak Hour	9:00 AM	to	10:00 AM
	5:15 PM		6:15 PM

Choose Time Period

7:00 to 8:00

= Total number by direction

= Total number of inbound and outbound traffic flows

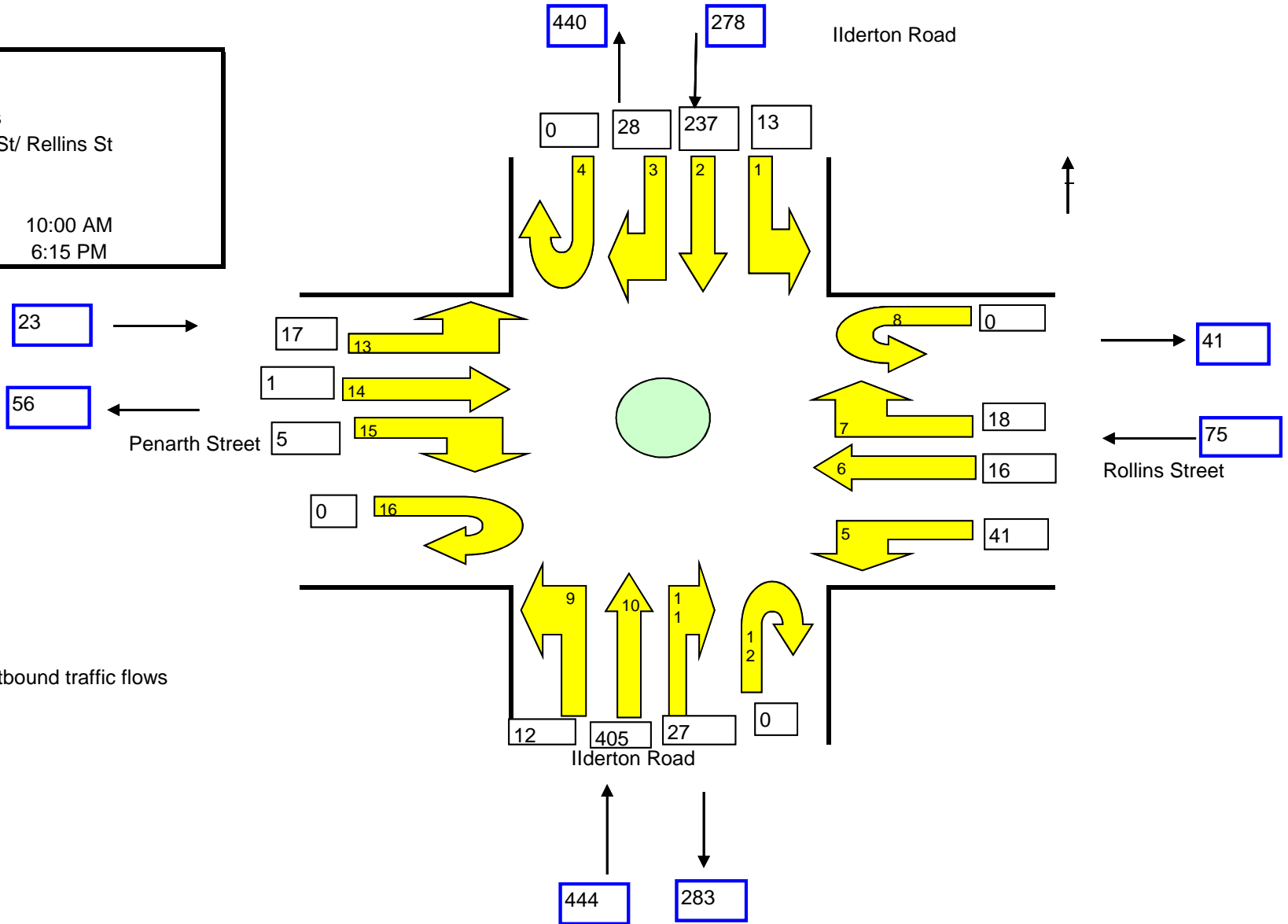



SKY HIGH LTD - THE TRAFFIC SURVEY COMPANY

AM 15 Minute Data Summary

Job :
Client : Peter Bretts Associates
Location : Surrey Canal Road/Excelsior Industrial Estate
Day : Thurs 09th July 2009
Weather : Fine
Peak Hour AM 7:30 AM to 8:30 AM

Vehicle Class Summary

Cars	Taxi	LGV	OGV1	OGV2	PSV	MC	Cycles
57.6%	1.0%	19.8%	8.7%	4.5%	0.0%	2.4%	6.0%

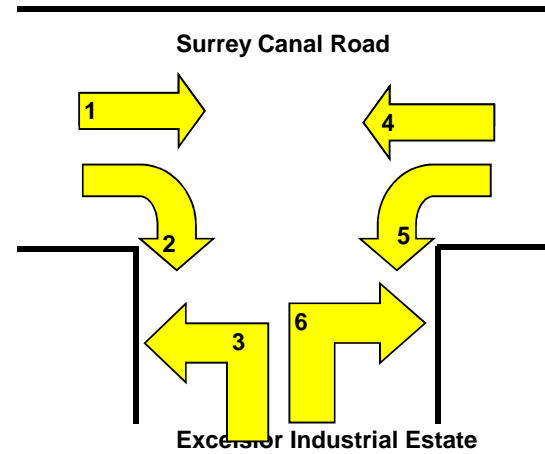

Time Period	Direction 4									Direction 5									Direction 6									
	Cars	Taxi	LGV	OGV1	OGV2	PSV	MC	Cycles	Total	Cars	Taxi	LGV	OGV1	OGV2	PSV	MC	Cycles	Total	Cars	Taxi	LGV	OGV1	OGV2	PSV	MC	Cycles	Total	
07:00 to 07:15	107	0	9	9	1	0	6	2	134	0	0	0	0	0	0	0	0	0	0	0	0	0	0	0	0	0	0	
07:15 to 07:30	78	0	20	10	4	0	4	3	119	0	0	0	0	0	0	0	0	0	0	0	0	0	0	0	0	0	0	
07:30 to 07:45	57	0	31	9	5	0	3	4	109	0	0	0	0	0	0	0	0	0	0	0	0	0	0	0	0	0	0	
07:45 to 08:00	64	0	23	10	8	0	2	11	118	0	0	0	0	0	0	0	0	0	0	0	0	0	0	0	0	0	0	
08:00 to 08:15	53	1	15	7	3	0	2	14	95	0	0	0	0	0	0	0	0	0	0	0	0	0	0	0	0	0	0	
08:15 to 08:30	58	1	25	13	4	0	4	27	132	0	0	0	0	0	0	0	0	0	0	0	0	0	0	0	0	0	0	
08:30 to 08:45	41	1	19	5	2	0	2	14	84	0	0	0	0	0	0	0	0	0	0	0	0	0	0	0	0	0	0	
08:45 to 09:00	42	2	20	6	3	0	0	6	79	2	0	1	1	1	0	0	1	6	0	0	0	0	0	0	0	0	0	
09:00 to 09:15	39	0	22	11	2	0	4	7	85	3	0	4	0	0	0	0	0	7	0	0	0	0	0	0	0	0	0	
09:15 to 09:30	62	1	16	9	5	0	0	12	105	0	0	1	0	0	0	0	0	1	0	0	1	0	0	0	0	1	2	
09:30 to 09:45	44	0	21	6	10	0	0	6	87	3	0	0	1	0	0	0	0	4	0	0	0	0	0	0	0	0	0	
09:45 to 10:00	44	1	14	6	3	0	4	0	72	2	0	0	0	0	0	0	0	2	2	0	0	0	0	0	0	0	2	
Survey Total	689	7	235	101	50	0	31	106	1219	10	0	6	2	1	0	0	1	20	2	0	1	0	0	0	0	0	1	4

PM 15 Minute Data Summary

Job :
Client : Peter Bretts Associates
Location : Surrey Canal Road/Excelsior Industrial Estate
Day : Thurs 09th July 2009
Weather : Fine
Peak Hour PM 5:00 PM to 6:00 PM

Vehicle Class Summary							
Cars	MC	LGV	OGV	OGV	PSV	MC	Cycle
70.2%	1.0%	18.1%	2.3%	0.3%	0.0%	2.8%	5.2%

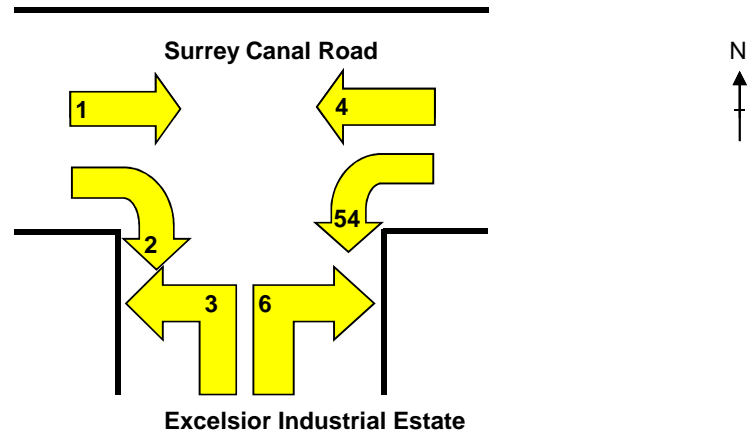

Time Period	Direction 4									Direction 5									Direction 6								
	Cars	Taxi	LGV	OGV1	OGV2	PSV	MC	Cycles	Total	Cars	Taxi	LGV	OGV1	OGV2	PSV	MC	Cycles	Total	Cars	Taxi	LGV	OGV1	OGV2	PSV	MC	Cycles	Total
16:00 to 16:15	60	2	14	5	1	0	0	1	83	1	0	1	0	0	0	0	0	2	3	0	2	0	0	0	0	0	5
16:15 to 16:30	60	1	13	5	1	0	1	2	83	0	0	0	0	0	0	0	0	0	2	1	0	1	0	0	0	1	5
16:30 to 16:45	58	1	9	3	1	0	0	0	72	0	0	0	0	0	0	0	1	1	2	0	2	0	0	0	1	0	5
16:45 to 17:00	57	0	15	5	0	0	1	3	81	0	0	0	0	0	0	0	0	0	3	1	0	0	0	0	0	0	4
17:00 to 17:15	87	1	11	0	2	0	2	2	105	4	0	1	0	0	0	0	0	5	6	0	0	0	0	0	0	1	7
17:15 to 17:30	65	0	7	0	0	0	3	8	83	0	0	0	0	0	0	0	0	0	2	0	0	0	0	0	0	1	3
17:30 to 17:45	63	0	12	2	0	0	3	7	87	0	0	0	0	0	0	0	0	0	2	0	0	0	0	0	0	0	2
17:45 to 18:00	74	0	8	2	1	0	5	4	94	0	0	0	0	0	0	0	0	0	1	0	3	0	0	0	0	0	4
18:00 to 18:15	73	0	7	0	0	0	3	3	86	1	0	0	0	0	0	0	0	1	2	0	0	0	0	0	0	0	2
18:15 to 18:30	76	1	11	0	0	0	6	4	98	1	0	0	0	0	0	0	0	1	0	0	0	0	0	0	0	0	0
18:30 to 18:45	86	0	10	2	1	0	1	4	104	0	0	0	0	0	0	0	0	0	1	0	0	0	0	0	0	0	1
18:45 to 19:00	60	2	6	0	1	0	1	3	73	0	0	0	0	0	0	0	0	0	0	0	1	0	0	0	0	0	1
Survey Total	819	8	123	24	8	0	26	41	1049	7	0	2	0	0	0	0	1	10	24	2	8	1	0	0	1	3	39

AM Hourly Summary

Job :
Client : Peter Bretts Associates
Location : Surrey Canal Road/Excelsior Industrial Estate
Day : Thurs 09th July 2009
Weather : Fine
Peak Hour AM 7:30 AM to 8:30 AM
Peak Hour PM 5:00 PM to 5:00PM

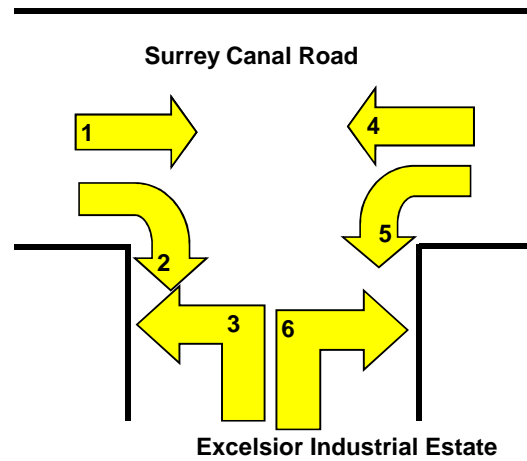

Time Period			Direction 1								Direction 2								Direction 3									
			Cars	Taxi	LGV	OGV1	OGV2	PSV	MC	Cycles	Total	Cars	Taxi	LGV	OGV1	OGV2	PSV	MC	Cycles	Total	Cars	Taxi	LGV	OGV1	OGV2	PSV	MC	Cycles
07:00	to	08:00	137	4	56	17	13	0	9	9	245	0	0	0	0	0	0	0	0	0	0	0	0	0	0	0	0	0
07:15	to	08:15	138	4	56	19	16	0	8	8	249	0	0	0	0	0	0	0	0	0	0	0	0	0	0	0	0	0
07:30	to	08:30	161	5	51	24	17	0	9	6	273	0	0	0	0	0	0	0	0	0	0	0	0	0	0	0	0	0
07:45	to	08:45	166	3	45	24	14	0	6	5	263	0	0	0	0	0	0	0	0	0	0	0	0	0	0	0	0	0
08:00	to	09:00	188	4	38	25	13	0	6	6	280	1	0	0	0	0	0	0	0	0	1	0	0	0	0	0	0	0
08:15	to	09:15	197	3	51	25	10	0	6	7	299	1	0	0	0	0	0	0	0	1	0	0	0	0	0	0	0	0
08:30	to	09:30	189	3	55	26	13	0	4	8	298	1	0	0	0	0	0	0	0	1	1	0	0	0	0	0	0	0
08:45	to	09:45	188	7	69	27	15	0	4	6	316	2	0	0	0	0	0	0	0	2	3	0	0	0	0	0	0	0
09:00	to	10:00	173	7	79	37	17	0	4	3	320	3	0	0	0	0	0	0	0	3	4	0	0	0	0	0	0	0

			Direction 4								Direction 5								Direction 6										
Time Period			Cars	Taxi	LGV	OGV1	OGV2	PSV	MC	Cycles	Total	Cars	Taxi	LGV	OGV1	OGV2	PSV	MC	Cycles	Total	Cars	Taxi	LGV	OGV1	OGV2	PSV	MC	Cycles	Total
07:00	to	08:00	306	0	83	38	18	0	15	20	480	0	0	0	0	0	0	0	0	0	0	0	0	0	0	0	0	0	0
07:15	to	08:15	252	1	89	36	20	0	11	32	441	0	0	0	0	0	0	0	0	0	0	0	0	0	0	0	0	0	0
07:30	to	08:30	232	2	94	39	20	0	11	56	454	0	0	0	0	0	0	0	0	0	0	0	0	0	0	0	0	0	0
07:45	to	08:45	216	3	82	35	17	0	10	66	429	0	0	0	0	0	0	0	0	0	0	0	0	0	0	0	0	0	0
08:00	to	09:00	194	5	79	31	12	0	8	61	390	2	0	1	1	1	0	0	1	6	0	0	0	0	0	0	0	0	0
08:15	to	09:15	180	4	86	35	11	0	10	54	380	5	0	5	1	1	0	0	1	13	0	0	0	0	0	0	0	0	0
08:30	to	09:30	184	4	77	31	12	0	6	39	353	5	0	6	1	1	0	0	1	14	0	0	1	0	0	0	0	1	2
08:45	to	09:45	187	3	79	32	20	0	4	31	356	8	0	6	2	1	0	0	1	18	0	0	1	0	0	0	0	1	2
09:00	to	10:00	189	2	73	32	20	0	8	25	349	8	0	5	1	0	0	0	0	14	2	0	1	0	0	0	0	1	4

PM Hourly Summary

Time Period			Direction 1								Direction 2								Direction 3									
			Cars	Taxi	LGV	OGV1	OGV2	PSV	MC	Cycles	Total	Cars	Taxi	LGV	OGV1	OGV2	PSV	MC	Cycles	Total	Cars	Taxi	LGV	OGV1	OGV2	PSV	MC	Cycles
16:00	to	17:00	504	7	224	31	3	0	18	9	796	1	0	0	0	0	0	0	1	2	0	0	0	0	0	0	0	2
16:15	to	17:15	509	8	214	24	3	0	17	22	797	0	0	0	0	0	0	0	0	3	0	0	0	0	0	0	3	
16:30	to	17:30	535	6	205	22	1	0	18	32	819	0	0	0	0	0	0	0	0	3	0	0	0	0	0	0	3	
16:45	to	17:45	551	8	181	17	1	0	25	37	820	0	0	0	0	0	0	0	0	2	0	0	0	0	0	0	2	
17:00	to	18:00	546	9	163	19	1	0	25	49	812	0	0	1	0	0	0	0	1	2	0	0	0	0	0	0	2	
17:15	to	18:15	564	8	147	14	0	0	25	52	810	0	0	1	0	0	0	0	1	1	0	0	0	0	0	0	1	
17:30	to	18:30	539	10	129	9	0	0	30	64	781	0	0	1	0	0	0	0	1	1	0	1	0	0	0	0	2	
17:45	to	18:45	532	9	122	7	0	0	26	71	767	0	0	1	0	0	0	0	1	1	0	1	0	0	0	0	2	
18:00	to	19:00	525	7	105	6	0	0	28	78	749	0	0	0	0	0	0	0	0	1	0	1	0	0	0	0	2	

PM Hourly Summary

Time Period			Direction 4								Direction 5								Direction 6										
			Cars	Taxi	LGV	OGV1	OGV2	PSV	MC	Cycles	Total	Cars	Taxi	LGV	OGV1	OGV2	PSV	MC	Cycles	Total	Cars	Taxi	LGV	OGV1	OGV2	PSV	MC	Cycles	Total
16:00	to	17:00	235	4	51	18	3	0	2	6	319	1	0	1	0	0	0	0	1	3	10	2	4	1	0	0	1	1	19
16:15	to	17:15	262	3	48	13	4	0	4	7	341	4	0	1	0	0	0	0	1	6	13	2	2	1	0	0	1	2	21
16:30	to	17:30	267	2	42	8	3	0	6	13	341	4	0	1	0	0	0	0	1	6	13	1	2	0	0	0	1	2	19
16:45	to	17:45	272	1	45	7	2	0	9	20	356	4	0	1	0	0	0	0	0	5	13	1	0	0	0	0	0	2	16
17:00	to	18:00	289	1	38	4	3	0	13	21	369	4	0	1	0	0	0	0	0	5	11	0	3	0	0	0	0	2	16
17:15	to	18:15	275	0	34	4	1	0	14	22	350	1	0	0	0	0	0	0	0	1	7	0	3	0	0	0	0	1	11
17:30	to	18:30	286	1	38	4	1	0	17	18	365	2	0	0	0	0	0	0	0	2	5	0	3	0	0	0	0	0	8
17:45	to	18:45	309	1	36	4	2	0	15	15	382	2	0	0	0	0	0	0	0	2	4	0	3	0	0	0	0	0	7
18:00	to	19:00	295	3	34	2	2	0	11	14	361	2	0	0	0	0	0	0	0	2	3	0	1	0	0	0	0	0	4



SKY HIGH LTD - THE TRAFFIC SURVEY COMPANY

Job :
Client : Peter Bretts Associates
Location : Surrey Canal Road/Excelsior Industrial E:
Day : Thurs 09th July 2009
Weather : Fine
Peak Hour AM : 7:30 AM to 8:30 AM
Peak Hour PM : 5:00 PM to 6:00 PM

Choose Time Period

7:00 to 8:00 ▼

= Total number by direction

= Total number of inbound and outbound traffic flows

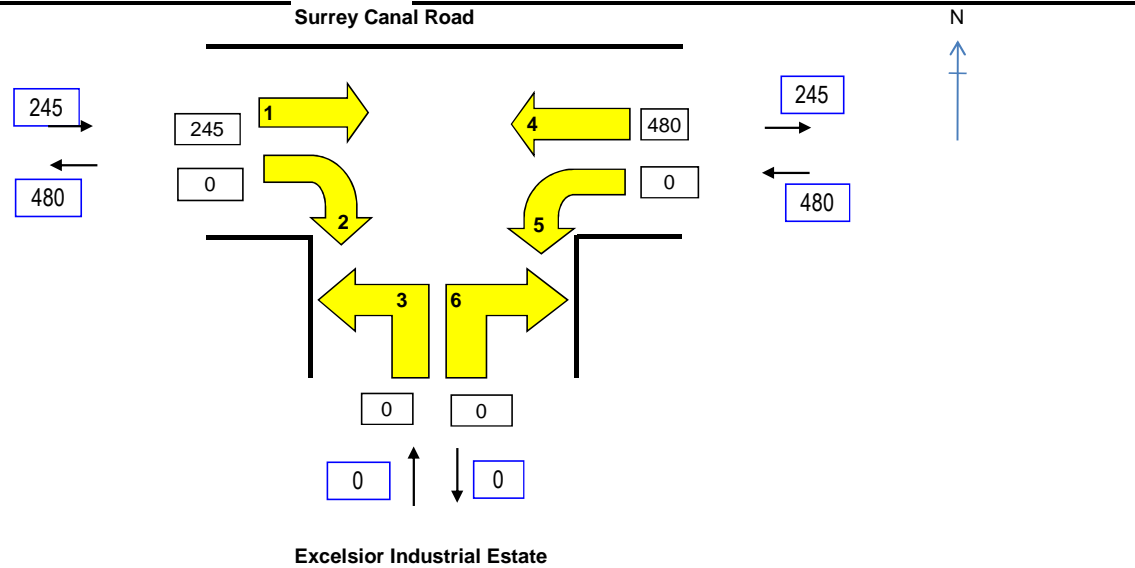



SKY HIGH LTD - THE TRAFFIC SURVEY COMPANY

AM 15 Minute Data Summary

Job :
Client : Peter Bretts Associates
Location : Surrey Canal Road/Orion Business Centre
Day : Thurs 09th July 2009
Weather : Fine
Peak Hour AM 5:00 PM to 6:00 PM

Vehicle Class Summary

Cars	Taxi	LGV	OGV1	OGV2	PSV	MC	Cycles
51.6%	1.0%	24.5%	9.5%	3.8%	0.0%	2.5%	7.0%

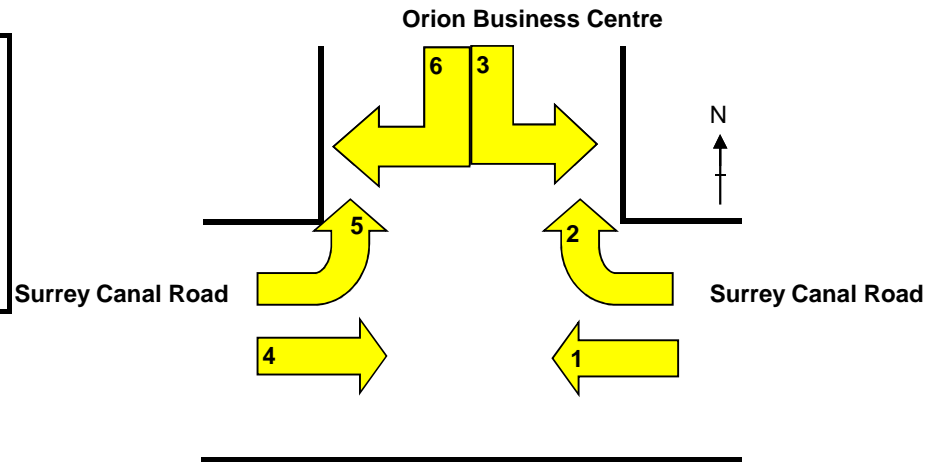

Time Period	Direction 1									Direction 2									Direction 3								
	Cars	Taxi	LGV	OGV1	OGV2	PSV	MC	Cycles	Total	Cars	Taxi	LGV	OGV1	OGV2	PSV	MC	Cycles	Total	Cars	Taxi	LGV	OGV1	OGV2	PSV	MC	Cycles	Total
07:00 to 07:15	53	1	53	11	5	0	4	2	129	1	0	0	0	0	0	0	0	1	0	0	0	0	0	0	0	0	0
07:15 to 07:30	58	0	33	8	4	0	5	7	115	0	0	0	0	0	0	0	1	1	1	0	0	0	0	0	0	0	1
07:30 to 07:45	53	1	41	10	2	0	3	6	116	0	0	0	0	0	0	0	0	0	0	0	0	0	0	0	0	0	0
07:45 to 08:00	65	0	23	13	4	0	1	16	122	1	1	1	1	0	0	0	0	4	0	0	0	0	0	0	0	0	0
08:00 to 08:15	47	1	18	11	3	0	3	14	97	2	0	0	0	0	0	0	0	2	0	0	0	0	0	0	0	0	0
08:15 to 08:30	61	0	26	7	3	0	8	27	132	1	1	1	0	0	0	0	0	3	1	0	0	0	0	0	0	0	1
08:30 to 08:45	51	0	23	9	1	0	3	18	105	0	0	2	0	0	0	0	0	2	0	0	1	0	0	0	0	0	1
08:45 to 09:00	48	1	30	7	2	0	1	18	107	0	0	1	0	0	0	0	0	1	0	0	0	0	0	0	0	0	0
09:00 to 09:15	42	0	20	14	2	0	3	10	91	0	0	2	0	0	0	0	0	2	0	0	1	0	0	0	0	0	1
09:15 to 09:30	58	1	21	12	1	0	2	11	106	1	0	0	0	0	0	0	0	1	0	0	1	0	0	0	0	0	1
09:30 to 09:45	54	0	22	12	7	0	0	7	102	1	1	0	0	0	0	0	0	2	0	0	2	1	0	0	0	0	3
09:45 to 10:00	45	0	12	6	2	0	4	2	71	0	0	0	0	0	0	0	0	0	0	0	3	0	0	0	0	0	3
Survey Total	635	5	322	120	36	0	37	138	1293	7	3	7	1	0	0	0	1	19	2	0	8	1	0	0	0	0	11

Time Period	Direction 4									Direction 5									Direction 6									
	Cars	Taxi	LGV	OGV1	OGV2	PSV	MC	Cycles	Total	Cars	Taxi	LGV	OGV1	OGV2	PSV	MC	Cycles	Total	Cars	Taxi	LGV	OGV1	OGV2	PSV	MC	Cycles	Total	
07:00 to 07:15	23	1	9	3	0	0	1	0	37	0	0	0	0	0	0	0	0	0	0	0	0	0	0	0	0	0	0	0
07:15 to 07:30	24	0	15	2	5	0	1	1	48	0	0	0	0	0	0	0	0	0	0	0	0	0	0	0	0	0	0	0
07:30 to 07:45	28	3	12	5	5	0	3	2	58	0	0	0	0	0	0	0	0	0	0	0	0	1	0	0	0	0	0	1
07:45 to 08:00	36	0	14	7	4	0	2	0	63	0	0	0	0	0	0	0	0	0	0	0	0	2	0	0	0	0	0	2
08:00 to 08:15	32	1	15	4	5	0	2	0	59	0	0	0	0	0	0	0	0	0	0	0	2	0	1	0	0	0	0	3
08:15 to 08:30	46	1	10	9	3	0	2	1	72	0	0	0	1	0	0	0	0	0	1	0	0	0	0	0	0	0	0	1
08:30 to 08:45	44	0	10	6	1	0	1	2	64	0	0	0	0	0	0	0	0	0	0	0	0	0	0	0	0	0	0	0
08:45 to 09:00	63	1	9	8	5	0	2	1	89	0	0	0	1	0	0	0	0	0	1	0	0	0	0	0	0	0	0	0
09:00 to 09:15	47	0	24	5	1	0	1	1	79	0	0	1	0	0	0	0	0	0	1	0	0	0	0	0	0	0	0	0
09:15 to 09:30	40	1	20	8	7	0	0	3	79	0	0	0	0	0	0	0	0	0	0	0	0	0	0	0	0	0	0	0
09:30 to 09:45	44	4	26	7	4	0	1	0	86	0	0	1	0	0	0	0	0	0	1	0	0	0	0	0	0	0	0	1
09:45 to 10:00	42	1	23	13	6	0	2	1	88	0	0	0	0	0	0	0	0	0	0	0	0	0	0	0	0	0	0	0
Survey Total	469	13	187	77	46	0	18	12	822	0	0	2	2	0	0	0	0	4	1	0	3	3	1	0	0	0	0	8

PM 15 Minute Data Summary

Job :
 Client : Peter Bretts Associates
 Location : Surrey Canal Road/Orion Business Centre
 Day : Thurs 09th July 2009
 Weather : Fine
 Peak Hour PM 5:00 PM to 6:00 PM

Vehicle Class Summary							
Cars	MC	LGV	OGV	OGV	PSV	MC	Cycle
72.3%	0.9%	16.7%	2.2%	0.3%	0.0%	2.9%	4.6%

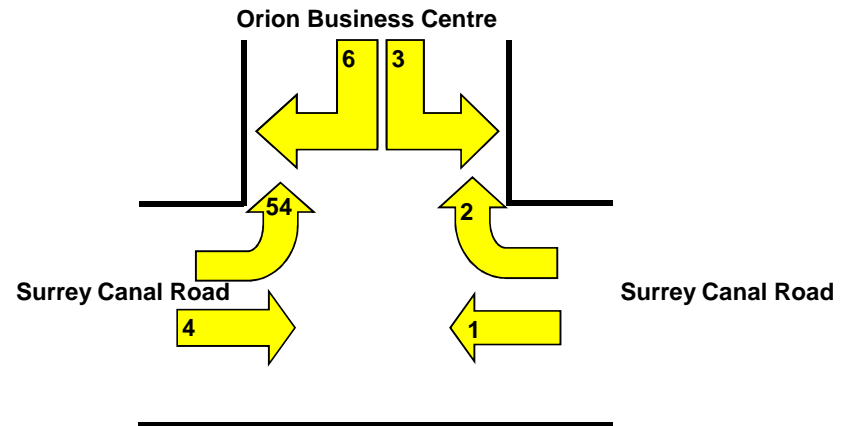

Time Period	Direction 1									Direction 2									Direction 3									
	Cars	Taxi	LGV	OGV1	OGV2	PSV	MC	Cycles	Total	Cars	Taxi	LGV	OGV1	OGV2	PSV	MC	Cycles	Total	Cars	Taxi	LGV	OGV1	OGV2	PSV	MC	Cycles	Total	
16:00 to 16:15	54	2	14	4	0	0	2	0	76	2	0	3	0	0	0	0	0	5	0	0	2	0	0	0	0	0	0	2
16:15 to 16:30	58	1	17	1	1	0	2	0	80	0	0	1	0	0	0	0	0	1	1	0	0	0	0	0	0	0	0	1
16:30 to 16:45	66	1	12	3	0	0	2	2	86	2	0	2	0	0	0	0	0	4	1	0	1	0	0	0	0	1	3	
16:45 to 17:00	62	1	15	3	0	0	1	5	87	0	0	0	0	0	0	0	0	0	0	0	3	0	0	0	0	0	3	
17:00 to 17:15	84	0	13	0	2	0	2	4	105	1	0	0	0	0	0	0	0	1	6	0	2	0	0	0	0	3	11	
17:15 to 17:30	57	0	7	1	0	0	3	7	75	0	0	0	0	0	0	0	0	0	0	0	1	0	0	0	0	0	1	
17:30 to 17:45	54	0	15	0	0	0	2	7	78	0	0	0	0	0	0	0	0	0	0	0	0	0	0	0	0	0	0	
17:45 to 18:00	83	0	10	1	1	0	5	2	102	1	0	0	0	0	0	0	0	1	1	0	0	0	0	0	0	0	1	
18:00 to 18:15	72	0	7	0	0	0	3	5	87	0	0	1	0	0	0	0	0	1	0	0	0	0	0	0	0	1	1	
18:15 to 18:30	78	1	10	0	0	0	5	6	100	0	0	0	0	0	0	0	0	0	0	0	1	0	0	0	0	1	2	
18:30 to 18:45	81	0	12	3	0	0	2	4	102	0	0	0	0	0	0	0	0	0	0	0	0	0	0	0	0	0	0	
18:45 to 19:00	68	1	8	0	1	0	0	3	81		0	0	0	0	0	0	0	0	0	0	0	0	0	0	1	1		
Survey Total	817	7	140	16	5	0	29	45	1059	6	0	7	0	0	0	0	0	13	9	0	10	0	0	0	0	7	26	

AM Hourly Summary

Job :
Client : Peter Bretts Associates
Location : Surrey Canal Road/Orion Business Centre
Day : Thurs 09th July 2009
Weather : Fine
Peak Hour AM 5:00 PM to 6:00 PM
Peak Hour PM 5:00 PM to 5:00PM

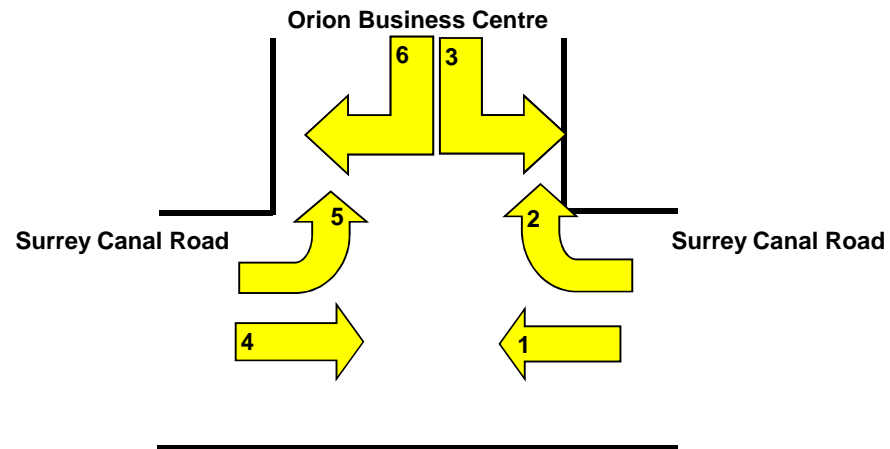

			Direction 1								Direction 2								Direction 3										
Time Period			Cars	Taxi	LGV	OGV1	OGV2	PSV	MC	Cycles	Total	Cars	Taxi	LGV	OGV1	OGV2	PSV	MC	Cycles	Total	Cars	Taxi	LGV	OGV1	OGV2	PSV	MC	Cycles	Total
07:00	to	08:00	229	2	150	42	15	0	13	31	482	2	1	1	1	0	0	0	1	6	1	0	0	0	0	0	0	0	1
07:15	to	08:15	223	2	115	42	13	0	12	43	450	3	1	1	1	0	0	0	1	7	1	0	0	0	0	0	0	0	1
07:30	to	08:30	226	2	108	41	12	0	15	63	467	4	2	2	1	0	0	0	0	9	1	0	0	0	0	0	0	0	1
07:45	to	08:45	224	1	90	40	11	0	15	75	456	4	2	4	1	0	0	0	0	11	1	0	1	0	0	0	0	0	2
08:00	to	09:00	207	2	97	34	9	0	15	77	441	3	1	4	0	0	0	0	0	8	1	0	1	0	0	0	0	0	2
08:15	to	09:15	202	1	99	37	8	0	15	73	435	1	1	6	0	0	0	0	0	8	1	0	2	0	0	0	0	0	3
08:30	to	09:30	199	2	94	42	6	0	9	57	409	1	0	5	0	0	0	0	0	6	0	0	3	0	0	0	0	0	3
08:45	to	09:45	202	2	93	45	12	0	6	46	406	2	1	3	0	0	0	0	0	6	0	0	4	1	0	0	0	0	5
09:00	to	10:00	199	1	75	44	12	0	9	30	370	2	1	2	0	0	0	0	0	5	0	0	7	1	0	0	0	0	8
			Direction 4								Direction 5								Direction 6										
Time Period			Cars	Taxi	LGV	OGV1	OGV2	PSV	MC	Cycles	Total	Cars	Taxi	LGV	OGV1	OGV2	PSV	MC	Cycles	Total	Cars	Taxi	LGV	OGV1	OGV2	PSV	MC	Cycles	Total
07:00	to	08:00	111	4	50	17	14	0	7	3	206	0	0	0	0	0	0	0	0	0	0	0	0	3	0	0	0	0	3
07:15	to	08:15	120	4	56	18	19	0	8	3	228	0	0	0	0	0	0	0	0	0	0	0	2	3	1	0	0	0	6
07:30	to	08:30	142	5	51	25	17	0	9	3	252	0	0	0	1	0	0	0	0	1	1	0	2	3	1	0	0	0	7
07:45	to	08:45	158	2	49	26	13	0	7	3	258	0	0	0	1	0	0	0	0	1	1	0	2	2	1	0	0	0	6
08:00	to	09:00	185	3	44	27	14	0	7	4	284	0	0	0	2	0	0	0	0	2	1	0	2	0	1	0	0	0	4
08:15	to	09:15	200	2	53	28	10	0	6	5	304	0	0	1	2	0	0	0	0	3	1	0	0	0	0	0	0	0	1
08:30	to	09:30	194	2	63	27	14	0	4	7	311	0	0	1	1	0	0	0	0	2	0	0	0	0	0	0	0	0	0
08:45	to	09:45	194	6	79	28	17	0	4	5	333	0	0	2	1	0	0	0	0	3	0	0	1	0	0	0	0	0	1
09:00	to	10:00	173	6	93	33	18	0	4	5	332	0	0	2	0	0	0	0	0	2	0	0	1	0	0	0	0	0	1

PM Hourly Summary

Time Period			Direction 1								Direction 2								Direction 3									
			Cars	Taxi	LGV	OGV1	OGV2	PSV	MC	Cycles	Total	Cars	Taxi	LGV	OGV1	OGV2	PSV	MC	Cycles	Total	Cars	Taxi	LGV	OGV1	OGV2	PSV	MC	Cycles
16:00	to	17:00	240	5	58	11	1	0	7	7	329	4	0	6	0	0	0	0	10	2	0	6	0	0	0	0	0	9
16:15	to	17:15	270	3	57	7	3	0	7	11	358	3	0	3	0	0	0	0	6	8	0	6	0	0	0	0	4	18
16:30	to	17:30	269	2	47	7	2	0	8	18	353	3	0	2	0	0	0	0	5	7	0	7	0	0	0	0	4	18
16:45	to	17:45	257	1	50	4	2	0	8	23	345	1	0	0	0	0	0	0	1	6	0	6	0	0	0	0	3	15
17:00	to	18:00	278	0	45	2	3	0	12	20	360	2	0	0	0	0	0	0	2	7	0	3	0	0	0	0	3	13
17:15	to	18:15	266	0	39	2	1	0	13	21	342	1	0	1	0	0	0	0	2	1	0	1	0	0	0	0	1	3
17:30	to	18:30	287	1	42	1	1	0	15	20	367	1	0	1	0	0	0	0	2	1	0	1	0	0	0	0	2	4
17:45	to	18:45	314	1	39	4	1	0	15	17	391	1	0	1	0	0	0	0	2	1	0	1	0	0	0	0	2	4
18:00	to	19:00	299	2	37	3	1	0	10	18	370	0	0	1	0	0	0	0	1	0	0	1	0	0	0	0	3	4



SKY HIGH LTD - THE TRAFFIC SURVEY COMPANY

Orion Business Centre

Job :
Client : Peter Bretts Associates
Location : Surrey Canal Road/Orion Business Centre
Day : Thurs 09th July 2009
Weather : Fine
Peak Hour AM 5:00 PM to 6:00 PM
Peak Hour PM 5:00 PM to 6:00 PM

Choose Time Period

7:00 to 8:00 ▼

 = Total number by direction

 = Total number of inbound and outbound traffic flows

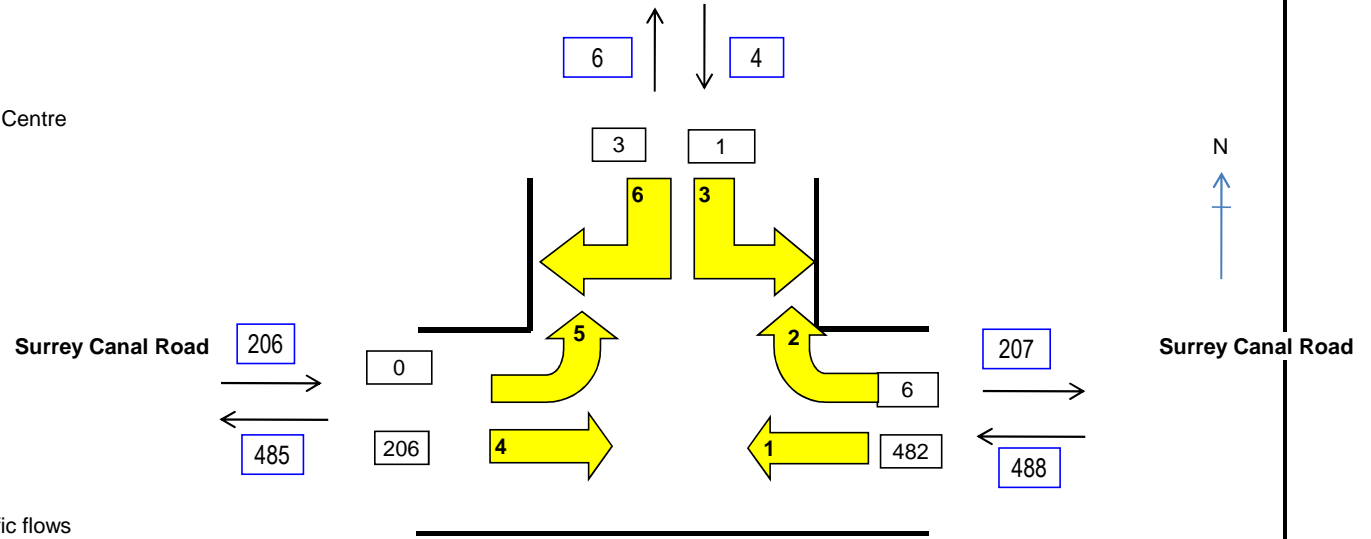



SKY HIGH LTD - THE TRAFFIC SURVEY COMPANY

AM 15 Minute Data Summary

Job :
Client : Peter Bretts Associates
Location : Surrey Canal Road/Mercury Way
Day : Thurs 09th July 2009
Weather : Fine
Peak Hour AM 8:15 AM to 9:15 AM

Vehicle Class Summary

Cats	Taxi	LGV	OGV1	OGV2	PSV	MC	Cycles
56.6%	0.8%	21.5%	9.7%	2.5%	0.0%	2.3%	6.6%

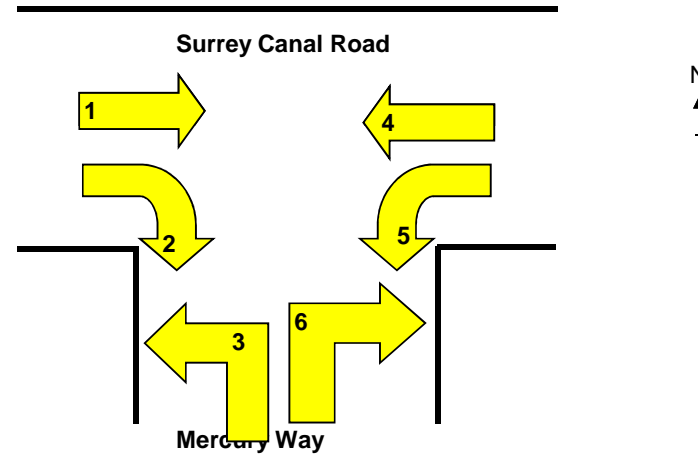

Time Period	Direction 1									Direction 2									Direction 3								
	Cars	Taxi	LGV	OGV1	OGV2	PSV	MC	Cycles	Total	Cars	Taxi	LGV	OGV1	OGV2	PSV	MC	Cycles	Total	Cars	Taxi	LGV	OGV1	OGV2	PSV	MC	Cycles	Total
07:00 to 07:15	23	1	10	4	1	0	3	0	42	6	0	2	0	0	0	0	0	8	3	0	1	5	0	0	0	1	10
07:15 to 07:30	24	0	11	6	0	0	1	0	42	4	0	0	1	0	0	0	0	5	3	0	0	2	0	0	0	4	9
07:30 to 07:45	28	3	17	5	2	0	4	0	59	4	0	1	1	0	0	0	0	6	2	0	2	4	0	0	0	0	8
07:45 to 08:00	36	0	16	7	0	0	2	0	61	1	0	1	3	0	0	0	1	6	4	0	1	4	0	0	0	2	11
08:00 to 08:15	32	0	11	7	0	0	2	0	52	3	0	1	2	0	0	0	0	6	3	0	0	4	1	0	0	0	8
08:15 to 08:30	46	1	10	8	0	0	2	0	67	2	0	2	2	0	0	0	0	6	4	0	2	1	0	0	1	8	16
08:30 to 08:45	39	1	9	4	1	0	1	0	55	6	0	0	1	0	0	0	0	7	5	0	0	1	0	0	1	6	13
08:45 to 09:00	53	1	10	3	1	0	2	0	70	5	0	2	6	0	0	0	0	13	3	0	3	0	0	0	0	4	10
09:00 to 09:15	40	0	23	4	0	0	1	0	68	7	0	2	3	0	0	0	0	12	4	0	2	3	0	0	0	1	10
09:15 to 09:30	30	1	14	11	1	0	0	0	57	4	0	1	4	0	0	0	0	9	4	0	2	5	0	0	0	5	16
09:30 to 09:45	37	4	20	11	1	0	1	0	74	5	0	2	0	0	0	0	0	7	1	0	1	1	0	0	0	0	3
09:45 to 10:00	41	1	21	11	1	0	2	0	77	2	0	1	7	0	0	0	0	10	0	0	0	1	0	0	0	0	1
Survey Total	429	13	172	81	8	0	21	0	724	49	0	15	30	0	0	0	1	95	36	0	14	31	1	0	2	31	115

Time Period	Direction 4									Direction 5									Direction 6								
	Cars	Taxi	LGV	OGV1	OGV2	PSV	MC	Cycles	Total	Cars	Taxi	LGV	OGV1	OGV2	PSV	MC	Cycles	Total	Cars	Taxi	LGV	OGV1	OGV2	PSV	MC	Cycles	Total
07:00 to 07:15	69	0	33	6	4	0	2	2	116	18	0	5	2	0	0	0	0	25	12	0	1	2	1	0	0	0	16
07:15 to 07:30	70	0	27	7	4	0	5	7	120	15	0	0	1	0	0	0	0	16	10	0	4	0	1	0	1	0	16
07:30 to 07:45	53	1	39	8	1	0	3	7	112	29	0	5	0	0	0	0	1	35	11	0	3	0	2	0	0	0	16
07:45 to 08:00	51	0	21	12	2	0	2	16	104	21	0	3	0	0	0	0	0	24	10	0	0	1	1	0	1	0	13
08:00 to 08:15	39	1	18	10	0	0	2	14	84	15	0	2	1	0	0	1	0	19	8	0	0	2	1	0	0	0	11
08:15 to 08:30	53	1	26	6	4	0	6	27	123	23	0	4	1	1	0	0	0	29	12	0	3	0	1	0	0	0	16
08:30 to 08:45	43	3	23	5	4	0	4	18	100	26	0	8	3	1	0	1	0	39	16	0	2	1	1	0	0	0	20
08:45 to 09:00	39	1	25	6	2	0	1	18	92	19	0	3	1	1	0	0	0	24	18	0	5	3	2	0	0	0	28
09:00 to 09:15	37	0	21	8	5	0	2	10	83	25	0	9	2	1	0	0	0	37	8	0	1	0	0	0	0	0	9
09:15 to 09:30	52	1	22	5	2	0	1	11	94	14	0	6	1	0	0	0	0	21	9	0	1	1	1	0	0	0	12
09:30 to 09:45	51	1	20	6	10	0	1	7	96	17	0	5	2	0	0	0	0	24	11	0	1	1	1	0	0	0	14
09:45 to 10:00	44	0	13	7	3	0	3	3	73	18	0	4	0	0	0	0	1	23	12	0	2	2	0	0	1	0	17
Survey Total	601	9	288	86	41	0	32	140	1197	240	0	54	14	4	0	2	2	316	137	0	23	13	12	0	3	0	188

PM 15 Minute Data Summary

Job :
 Client : Peter Bretts Associates
 Location : Surrey Canal Road/Mercury Way
 Day : Thurs 09th July 2009
 Weather : Fine
 Peak Hour PM 4:30 PM to 5:30 PM

Vehicle Class Summary							
Cars	MC	LGV	OGV	OGV	PSV	MC	Cycle
73.8%	0.8%	17.8%	2.3%	0.3%	0.1%	2.5%	2.4%

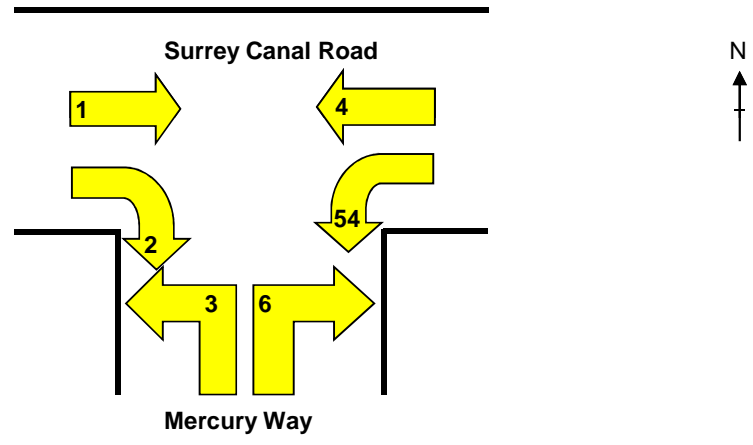

Time Period	Direction 1									Direction 2									Direction 3								
	Cars	Taxi	LGV	OGV1	OGV2	PSV	MC	Cycles	Total	Cars	Taxi	LGV	OGV1	OGV2	PSV	MC	Cycles	Total	Cars	Taxi	LGV	OGV1	OGV2	PSV	MC	Cycles	Total
16:00 to 16:15	99	0	41	7	2	0	5	0	154	5	0	1	0	0	0	1	0	7	1	0	2	0	0	0	0	0	3
16:15 to 16:30	117	2	61	10	2	0	2	0	194	5	0	1	1	1	0	0	0	8	3	0	0	0	0	0	0	0	3
16:30 to 16:45	140	1	59	9	0	0	2	2	213	12	0	2	0	0	0	0	1	15	1	0	0	0	0	0	0	0	1
16:45 to 17:00	121	3	52	2	0	0	7	0	185	13	0	2	0	0	0	0	0	15	4	0	0	0	0	0	0	0	4
17:00 to 17:15	116	2	45	8	0	0	6	0	177	9	0	0	0	0	0	0	3	12	1	0	1	0	0	0	0	0	2
17:15 to 17:30	144	0	54	7	0	0	3	0	208	11	0	3	0	0	0	0	2	16	3	0	1	0	0	0	1	2	7
17:30 to 17:45	135	3	29	6	0	0	9	3	185	13	0	1	0	0	0	1	1	16	0	0	0	0	0	0	0	0	0
17:45 to 18:00	116	3	38	5	0	0	5	1	168	13	0	1	0	0	0	0	3	17	2	0	0	0	0	0	1	0	3
18:00 to 18:15	134	2	29	1	0	0	5	0	171	12	0	3	1	0	0	0	3	19	1	0	0	0	0	0	0	1	2
18:15 to 18:30	106	2	32	4	0	0	6	1	151	14	0	0	0	0	0	2	10	26	2	0	0	0	0	0	0	0	2
18:30 to 18:45	128	1	27	3	1	0	4	3	167	10	1	1	0	0	0	1	4	17	3	0	0	0	0	0	0	0	3
18:45 to 19:00	105	1	20	3	0	0	8	1	138	14	1	2	0	0	0	0	5	22	5	0	0	0	0	0	0	0	5
Survey Total	1461	20	487	65	5	0	62	11	2111	131	2	17	2	1	0	5	32	190	26	0	4	0	0	0	2	3	35

Time Period	Direction 4									Direction 5									Direction 6								
	Cars	Taxi	LGV	OGV1	OGV2	PSV	MC	Cycles	Total	Cars	Taxi	LGV	OGV1	OGV2	PSV	MC	Cycles	Total	Cars	Taxi	LGV	OGV1	OGV2	PSV	MC	Cycles	Total
16:00 to 16:15	47	1	16	3	1	0	1	0	69	22	1	4	0	0	1	2	0	30	21	0	1	4	0	0	0	0	26
16:15 to 16:30	52	1	14	3	1	0	2	0	73	22	0	5	0	0	0	0	0	27	28	0	1	0	0	0	0	0	29
16:30 to 16:45	56	1	13	3	0	0	1	1	75	33	0	7	0	0	0	0	0	40	13	0	3	0	0	0	0	0	16
16:45 to 17:00	60	0	16	4	0	0	1	5	86	31	0	2	0	0	0	0	0	33	28	0	4	0	0	0	1	0	33
17:00 to 17:15	70	1	10	1	2	0	1	4	89	29	1	5	0	0	0	0	0	35	27	0	4	0	0	0	1	0	32
17:15 to 17:30	57	0	8	2	0	0	2	7	76	23	0	0	0	0	0	0	0	23	25	0	2	0	0	0	0	0	27
17:30 to 17:45	59	0	14	1	0	0	2	7	83	26	0	3	0	0	1	0	1	31	17	0	1	1	0	0	0	0	19
17:45 to 18:00	73	0	9	1	1	0	4	2	90	28	0	4	0	0	0	0	0	32	12	0	3	0	0	0	0	0	15
18:00 to 18:15	65	0	6	0	0	0	3	5	79	30	0	1	0	0	0	1	0	32	23	0	1	0	0	0	0	0	24
18:15 to 18:30	71	1	10	0	0	0	5	6	93	24	0	6	0	0	0	0	0	30	10	0	1	0	0	0	0	0	11
18:30 to 18:45	70	0	9	2	1	0	1	4	87	39	0	1	0	0	0	0	1	41	22	0	3	0	0	0	0	0	25
18:45 to 19:00	57	1	3	0	1	0	1	3	66	25	1	5	0	0	0	0	3	34	17	0	5	0	0	0	0	0	22
Survey Total	737	6	128	20	7	0	24	44	966	332	3	43	0	0	2	3	5	388	243	0	29	5	0	0	2	0	279

AM Hourly Summary

Job :
Client : Peter Bretts Associates
Location : Surrey Canal Road/Mercury Way
Day : Thurs 09th July 2009
Weather : Fine
Peak Hour AM 8:15 AM to 9:15 AM
Peak Hour PM 4:30 PM to 5:00PM

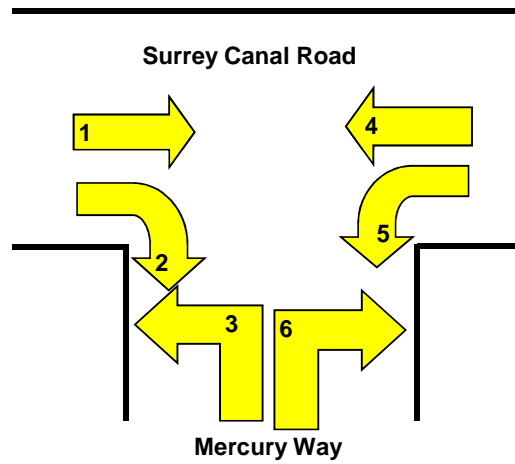

Time Period			Direction 1								Direction 2								Direction 3										
			Cars	Taxi	LGV	OGV1	OGV2	PSV	MC	Cycles	Total	Cars	Taxi	LGV	OGV1	OGV2	PSV	MC	Cycles	Total	Cars	Taxi	LGV	OGV1	OGV2	PSV	MC	Cycles	Total
07:00	to	08:00	111	4	54	22	3	0	10	0	204	15	0	4	5	0	0	0	1	25	12	0	4	15	0	0	0	7	38
07:15	to	08:15	120	3	55	25	2	0	9	0	214	12	0	3	7	0	0	0	1	23	12	0	3	14	1	0	0	6	36
07:30	to	08:30	142	4	54	27	2	0	10	0	239	10	0	5	8	0	0	0	1	24	13	0	5	13	1	0	1	10	43
07:45	to	08:45	153	2	46	26	1	0	7	0	235	12	0	4	8	0	0	0	1	25	16	0	3	10	1	0	2	16	48
08:00	to	09:00	170	3	40	22	2	0	7	0	244	16	0	5	11	0	0	0	0	32	15	0	5	6	1	0	2	18	47
08:15	to	09:15	178	3	52	19	2	0	6	0	260	20	0	6	12	0	0	0	0	38	16	0	7	5	0	0	2	19	49
08:30	to	09:30	162	3	56	22	3	0	4	0	250	22	0	5	14	0	0	0	0	41	16	0	7	9	0	0	1	16	49
08:45	to	09:45	160	6	67	29	3	0	4	0	269	21	0	7	13	0	0	0	0	41	12	0	8	9	0	0	0	10	39
09:00	to	10:00	148	6	78	37	3	0	4	0	276	18	0	6	14	0	0	0	0	38	9	0	5	10	0	0	0	6	30

Time Period			Direction 4								Direction 5								Direction 6										
			Cars	Taxi	LGV	OGV1	OGV2	PSV	MC	Cycles	Total	Cars	Taxi	LGV	OGV1	OGV2	PSV	MC	Cycles	Total	Cars	Taxi	LGV	OGV1	OGV2	PSV	MC	Cycles	Total
07:00	to	08:00	243	1	120	33	11	0	12	32	452	83	0	13	3	0	0	0	1	100	43	0	8	3	5	0	2	0	61
07:15	to	08:15	213	2	105	37	7	0	12	44	420	80	0	10	2	0	0	1	1	94	39	0	7	3	5	0	2	0	56
07:30	to	08:30	196	3	104	36	7	0	13	64	423	88	0	14	2	1	0	1	1	107	41	0	6	3	5	0	1	0	56
07:45	to	08:45	186	5	88	33	10	0	14	75	411	85	0	17	5	2	0	2	0	111	46	0	5	4	4	0	1	0	60
08:00	to	09:00	174	6	92	27	10	0	13	77	399	83	0	17	6	3	0	2	0	111	54	0	10	6	5	0	0	0	75
08:15	to	09:15	172	5	95	25	15	0	13	73	398	93	0	24	7	4	0	1	0	129	54	0	11	4	4	0	0	0	73
08:30	to	09:30	171	5	91	24	13	0	8	57	369	84	0	26	7	3	0	1	0	121	51	0	9	5	4	0	0	0	69
08:45	to	09:45	179	3	88	25	19	0	5	46	365	75	0	23	6	2	0	0	0	106	46	0	8	5	4	0	0	0	63
09:00	to	10:00	184	2	76	26	20	0	7	31	346	74	0	24	5	1	0	0	1	105	40	0	5	4	2	0	1	0	52

PM Hourly Summary

Time Period			Direction 1								Direction 2								Direction 3										
			Cars	Taxi	LGV	OGV1	OGV2	PSV	MC	Cycles	Total	Cars	Taxi	LGV	OGV1	OGV2	PSV	MC	Cycles	Total	Cars	Taxi	LGV	OGV1	OGV2	PSV	MC	Cycles	Total
16:00	to	17:00	477	6	213	28	4	0	16	2	746	35	0	6	1	1	0	1	1	45	9	0	2	0	0	0	0	0	11
16:15	to	17:15	494	8	217	29	2	0	17	2	769	39	0	5	1	1	0	0	4	50	9	0	1	0	0	0	0	0	10
16:30	to	17:30	521	6	210	26	0	0	18	2	783	45	0	7	0	0	0	0	6	58	9	0	2	0	0	0	1	2	14
16:45	to	17:45	516	8	180	23	0	0	25	3	755	46	0	6	0	0	0	1	6	59	8	0	2	0	0	0	1	2	13
17:00	to	18:00	511	8	166	26	0	0	23	4	738	46	0	5	0	0	0	1	9	61	6	0	2	0	0	0	2	2	12
17:15	to	18:15	529	8	150	19	0	0	22	4	732	49	0	8	1	0	0	1	9	68	6	0	1	0	0	0	2	3	12
17:30	to	18:30	491	10	128	16	0	0	25	5	675	52	0	5	1	0	0	3	17	78	5	0	0	0	0	0	1	1	7
17:45	to	18:45	484	8	126	13	1	0	20	5	657	49	1	5	1	0	0	3	20	79	8	0	0	0	0	0	1	1	10
18:00	to	19:00	473	6	108	11	1	0	23	5	627	50	2	6	1	0	0	3	22	84	11	0	0	0	0	0	0	1	12

PM Hourly Summary

Time Period			Direction 4								Direction 5								Direction 6										
			Cars	Taxi	LGV	OGV1	OGV2	PSV	MC	Cycles	Total	Cars	Taxi	LGV	OGV1	OGV2	PSV	MC	Cycles	Total	Cars	Taxi	LGV	OGV1	OGV2	PSV	MC	Cycles	Total
16:00	to	17:00	215	3	59	13	2	0	5	6	303	108	1	18	0	0	1	2	0	130	90	0	9	4	0	0	1	0	104
16:15	to	17:15	238	3	53	11	3	0	5	10	323	115	1	19	0	0	0	0	0	135	96	0	12	0	0	0	2	0	110
16:30	to	17:30	243	2	47	10	2	0	5	17	326	116	1	14	0	0	0	0	0	131	93	0	13	0	0	0	2	0	108
16:45	to	17:45	246	1	48	8	2	0	6	23	334	109	1	10	0	0	1	0	1	122	97	0	11	1	0	0	2	0	111
17:00	to	18:00	259	1	41	5	3	0	9	20	338	106	1	12	0	0	1	0	1	121	81	0	10	1	0	0	1	0	93
17:15	to	18:15	254	0	37	4	1	0	11	21	328	107	0	8	0	0	1	1	1	118	77	0	7	1	0	0	0	0	85
17:30	to	18:30	268	1	39	2	1	0	14	20	345	108	0	14	0	0	1	1	1	125	62	0	6	1	0	0	0	0	69
17:45	to	18:45	279	1	34	3	2	0	13	17	349	121	0	12	0	0	0	1	1	135	67	0	8	0	0	0	0	0	75
18:00	to	19:00	263	2	28	2	2	0	10	18	325	118	1	13	0	0	0	1	4	137	72	0	10	0	0	0	0	0	82





SKY HIGH LTD - THE TRAFFIC SURVEY COMPANY

Job :
Client : Peter Bretts Associates
Location : Surrey Canal Road/Mercury Way
Day : Thurs 09th July 2009
Weather : Fine
Peak Hour AM : 8:15 AM to 9:15 AM
Peak Hour PM : 4:30 PM to 5:30 PM

Choose Time Period

7:00 to 8:00 ▼

 = Total number by direction

 = Total number of inbound and outbound traffic flows

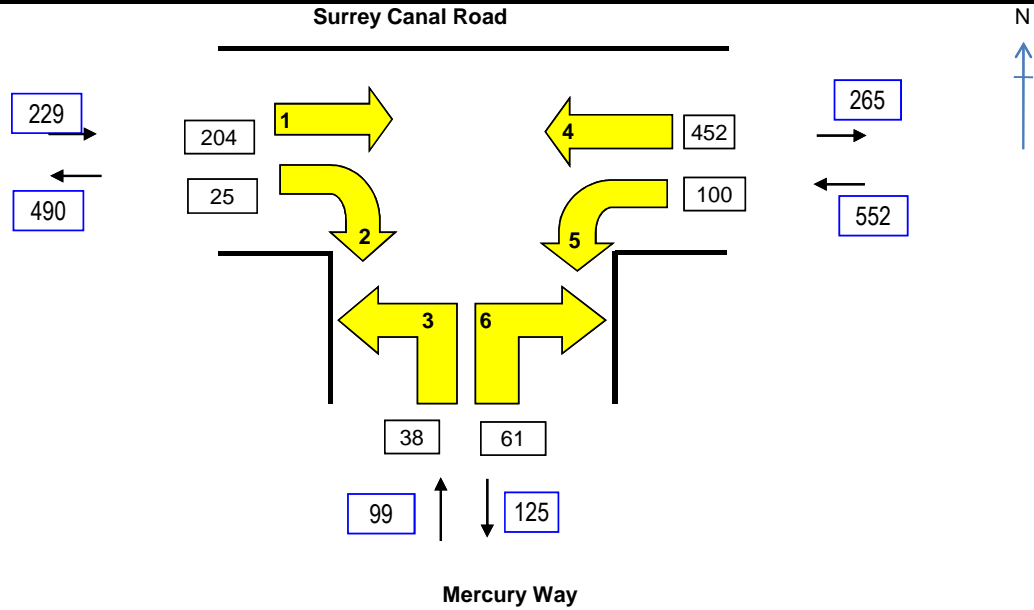



SKY HIGH LTD - THE TRAFFIC SURVEY COMPANY

AM 15 Minute Data Summary

Job :
Client : Peter Bretts Associates
Location : Rollins Street/Lovelinch Close
Day : Thurs 09th July 2009
Weather : Fine
Peak Hour AM 8:30 AM to 9:30 AM

Vehicle Class Summary

Cats	Taxi	LGV	OGV1	OGV2	PSV	MC	Cycles
51.7%	0.0%	21.1%	20.4%	2.7%	0.0%	0.7%	3.4%

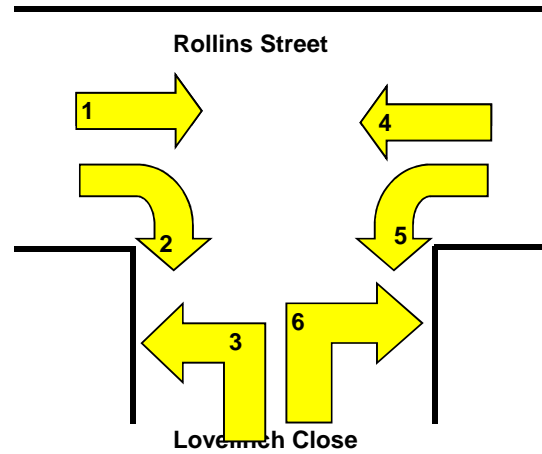

Time Period	Direction 1									Direction 2									Direction 3								
	Cars	Taxi	LGV	OGV1	OGV2	PSV	MC	Cycles	Total	Cars	Taxi	LGV	OGV1	OGV2	PSV	MC	Cycles	Total	Cars	Taxi	LGV	OGV1	OGV2	PSV	MC	Cycles	Total
07:00 to 07:15	1	0	1	1	0	0	0	0	3	1	0	0	0	0	0	0	0	1	0	0	1	0	0	0	0	0	1
07:15 to 07:30	1	0	1	3	0	0	0	0	5	0	0	0	1	0	0	0	0	1	3	0	0	0	0	0	0	0	3
07:30 to 07:45	2	0	2	0	0	0	0	0	4	0	0	0	0	0	0	0	0	0	1	0	2	0	0	0	0	1	4
07:45 to 08:00	2	0	0	0	0	0	0	0	2	1	0	1	0	0	0	0	0	2	2	0	1	0	0	0	0	0	3
08:00 to 08:15	4	0	2	0	0	0	0	0	6	0	0	0	0	0	0	0	0	0	1	0	0	0	0	0	0	1	2
08:15 to 08:30	1	0	0	0	0	0	0	0	1	0	0	0	0	0	0	0	0	0	6	0	0	0	0	0	0	0	6
08:30 to 08:45	2	0	1	2	1	0	0	0	6	1	0	1	0	0	0	0	0	2	4	0	0	0	0	0	0	0	4
08:45 to 09:00	0	0	0	0	0	0	0	0	0	2	0	1	0	0	0	0	0	3	3	0	1	0	0	0	0	0	4
09:00 to 09:15	3	0	1	2	0	0	0	2	8	1	0	0	0	0	0	0	0	1	2	0	0	0	0	0	0	0	2
09:15 to 09:30	3	0	2	0	0	0	0	0	5	0	0	1	1	0	0	0	0	2	0	0	1	0	0	0	0	0	1
09:30 to 09:45	2	0	0	1	0	0	0	0	3	0	0	0	0	0	0	0	0	0	0	0	0	0	0	0	0	0	0
09:45 to 10:00	2	0	0	2	1	0	0	0	5	1	0	0	0	0	0	0	0	1	1	0	0	3	0	0	1	0	5
Survey Total	23	0	10	11	2	0	0	2	48	7	0	4	2	0	0	0	0	13	23	0	6	3	0	0	1	2	35

Time Period	Direction 4									Direction 5									Direction 6								
	Cars	Taxi	LGV	OGV1	OGV2	PSV	MC	Cycles	Total	Cars	Taxi	LGV	OGV1	OGV2	PSV	MC	Cycles	Total	Cars	Taxi	LGV	OGV1	OGV2	PSV	MC	Cycles	Total
07:00 to 07:15	2	0	0	2	0	0	0	0	4	0	0	0	0	0	0	0	1	1	0	0	0	0	0	0	0	0	0
07:15 to 07:30	0	0	1	1	0	0	0	0	2	0	0	0	0	0	0	0	0	0	0	0	1	0	0	0	0	0	1
07:30 to 07:45	3	0	0	2	0	0	0	0	5	0	0	0	0	0	0	0	0	0	0	0	0	0	0	0	0	0	0
07:45 to 08:00	3	0	0	0	0	0	0	0	3	0	0	0	0	0	0	0	0	0	0	0	0	1	0	0	0	0	1
08:00 to 08:15	1	0	1	0	0	0	0	0	2	0	0	0	0	0	0	0	0	0	0	0	0	0	0	0	0	0	0
08:15 to 08:30	0	0	1	2	0	0	0	0	3	0	0	0	0	0	0	0	0	0	0	0	0	0	0	0	0	0	0
08:30 to 08:45	0	0	0	1	0	0	0	0	1	0	0	0	0	0	0	0	0	0	0	0	0	0	0	0	0	0	0
08:45 to 09:00	2	0	2	1	1	0	0	0	6	0	0	0	1	0	0	0	0	1	0	0	0	0	0	0	0	0	0
09:00 to 09:15	4	0	2	1	0	0	0	0	7	0	0	0	0	0	0	0	0	0	0	0	0	0	0	0	0	0	0
09:15 to 09:30	1	0	2	0	0	0	0	0	3	0	0	0	0	0	0	0	0	0	0	0	0	0	0	0	0	0	0
09:30 to 09:45	2	0	0	2	1	0	0	0	5	0	0	0	0	0	0	0	0	0	0	0	0	0	0	0	0	0	0
09:45 to 10:00	5	0	1	0	0	0	0	0	6	0	0	0	0	0	0	0	0	0	0	0	0	0	0	0	0	0	0
Survey Total	23	0	10	12	2	0	0	0	47	0	0	0	1	0	0	0	1	2	0	0	1	1	0	0	0	0	2

PM 15 Minute Data Summary

Job :
Client : Peter Bretts Associates
Location : Rollins Street/Lovelinch Close
Day : Thurs 09th July 2009
Weather : Fine
Peak Hour PM 4:15 PM to 5:15 PM

Vehicle Class Summary							
Cars	MC	LGV	OGV	OGV	PSV	MC	Cycle
64.1%	0.0%	26.1%	5.4%	0.0%	0.0%	2.7%	1.6%

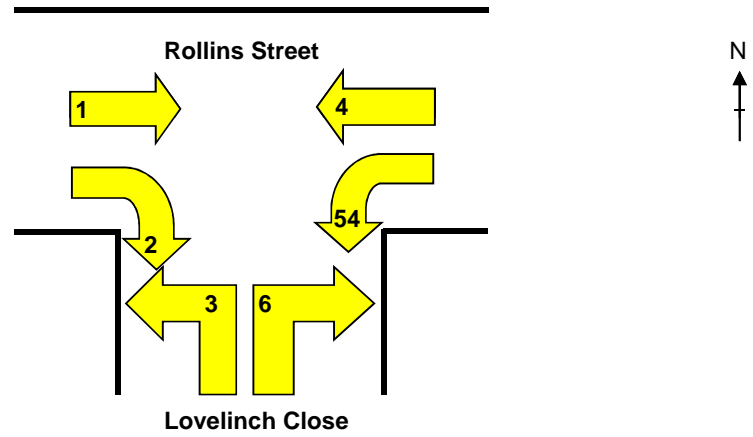

Time Period	Direction 1									Direction 2									Direction 3								
	Cars	Taxi	LGV	OGV1	OGV2	PSV	MC	Cycles	Total	Cars	Taxi	LGV	OGV1	OGV2	PSV	MC	Cycles	Total	Cars	Taxi	LGV	OGV1	OGV2	PSV	MC	Cycles	Total
16:00 to 16:15	7	0	2	2	0	0	0	0	11	3	0	0	0	0	0	0	0	3	2	0	0	0	0	0	0	0	2
16:15 to 16:30	2	0	2	2	0	0	0	0	6	3	0	0	1	0	0	0	0	4	1	0	0	0	0	0	0	0	1
16:30 to 16:45	1	0	4	0	0	0	0	0	5	1	0	0	1	0	0	0	0	2	3	0	0	0	0	0	0	0	3
16:45 to 17:00	5	0	2	0	0	0	0	0	7	1	0	1	0	0	0	0	0	2	2	0	2	0	0	0	0	1	5
17:00 to 17:15	4	0	3	0	0	0	0	0	7	4	0	0	0	0	0	1	0	5	2	0	0	0	0	0	2	0	4
17:15 to 17:30	1	0	1	0	0	0	0	0	2	1	0	1	0	0	0	0	0	2	2	0	1	0	0	0	0	0	3
17:30 to 17:45	1	0	1	0	0	0	0	0	2	3	0	0	0	0	0	0	2	5	2	0	0	0	0	0	0	0	2
17:45 to 18:00	1	0	2	1	0	0	0	0	4	4	0	2	0	0	0	1	0	7	2	0	2	0	0	0	0	0	4
18:00 to 18:15	1	0	0	0	0	0	0	0	1	2	0	0	0	0	0	0	0	2	3	0	1	0	0	0	0	0	4
18:15 to 18:30	3	0	0	0	0	0	0	0	3	4	0	0	0	0	0	0	0	4	5	0	0	0	0	0	0	0	5
18:30 to 18:45	2	0	1	0	0	0	0	0	3	2	0	0	0	0	0	0	0	2	1	0	0	0	0	0	0	0	1
18:45 to 19:00	1	0	0	0	0	0	0	0	1	2	0	1	0	0	0	0	0	3	3	0	2	0	0	0	0	0	5
Survey Total	29	0	18	5	0	0	0	0	52	30	0	5	2	0	0	2	2	41	28	0	8	0	0	0	2	1	39

Time Period	Direction 4									Direction 5									Direction 6									
	Cars	Taxi	LGV	OGV1	OGV2	PSV	MC	Cycles	Total	Cars	Taxi	LGV	OGV1	OGV2	PSV	MC	Cycles	Total	Cars	Taxi	LGV	OGV1	OGV2	PSV	MC	Cycles	Total	
16:00 to 16:15	1	0	1	0	0	0	0	0	2	3	0	0	0	0	0	0	0	3	2	0	0	0	0	0	0	0	0	2
16:15 to 16:30	2	0	1	1	0	0	0	0	4	0	0	0	0	0	0	0	0	0	1	0	0	0	0	0	0	0	0	1
16:30 to 16:45	0	0	3	0	0	0	0	0	3	0	0	0	0	0	0	0	0	0	0	0	0	0	0	0	0	1	0	1
16:45 to 17:00	2	0	1	1	0	0	0	0	4	0	0	0	0	0	0	0	0	0	0	0	1	0	0	0	0	0	0	1
17:00 to 17:15	5	0	2	0	0	0	0	0	7	0	0	0	0	0	0	0	0	0	1	0	0	0	0	0	0	0	0	1
17:15 to 17:30	2	0	1	0	0	0	0	0	3	0	0	0	0	0	0	0	0	0	0	0	1	1	0	0	0	0	0	2
17:30 to 17:45	0	0	4	0	0	0	0	0	4	0	0	0	0	0	0	0	0	0	1	0	0	0	0	0	0	0	0	1
17:45 to 18:00	2	0	1	0	0	0	0	0	3	0	0	0	0	0	0	0	0	0	0	0	1	0	0	0	0	0	0	1
18:00 to 18:15	3	0	0	0	0	0	0	0	3	0	0	0	0	0	0	0	0	0	0	0	0	0	0	0	0	0	0	0
18:15 to 18:30	2	0	0	0	0	0	0	0	2	0	0	0	0	0	0	0	0	0	0	0	0	0	0	0	0	0	0	0
18:30 to 18:45	1	0	0	0	0	0	0	0	1	0	0	0	0	0	0	0	0	0	0	0	0	0	0	0	0	0	0	0
18:45 to 19:00	3	0	0	0	0	0	0	0	3	0	0	0	0	0	0	0	0	0	0	0	0	0	0	0	0	0	0	0
Survey Total	23	0	14	2	0	0	0	0	39	3	0	0	0	0	0	0	0	3	5	0	3	1	0	0	1	0	10	

AM Hourly Summary

Job :
Client : Peter Bretts Associates
Location : Rollins Street/Lovelinch Close
Day : Thurs 09th July 2009
Weather : Fine
Peak Hour AM 8:30 AM to 9:30 AM
Peak Hour PM 4:15 PM to 5:00PM

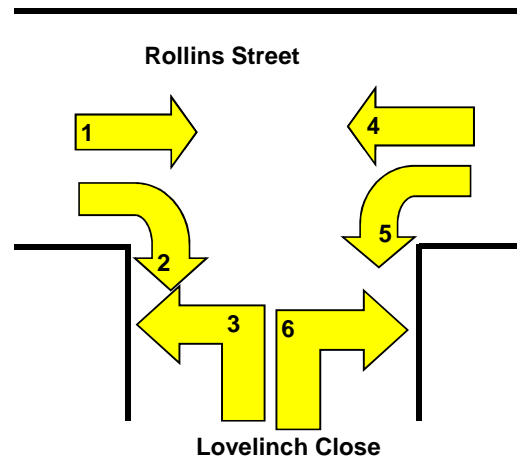

Time Period			Direction 1								Direction 2								Direction 3									
			Cars	Taxi	LGV	OGV1	OGV2	PSV	MC	Cycles	Total	Cars	Taxi	LGV	OGV1	OGV2	PSV	MC	Cycles	Total	Cars	Taxi	LGV	OGV1	OGV2	PSV	MC	Cycles
07:00	to	08:00	6	0	4	4	0	0	0	14	2	0	1	1	0	0	0	0	4	6	0	4	0	0	0	0	1	11
07:15	to	08:15	9	0	5	3	0	0	0	17	1	0	1	1	0	0	0	0	3	7	0	3	0	0	0	0	2	12
07:30	to	08:30	9	0	4	0	0	0	0	13	1	0	1	0	0	0	0	0	2	10	0	3	0	0	0	0	2	15
07:45	to	08:45	9	0	3	2	1	0	0	15	2	0	2	0	0	0	0	0	4	13	0	1	0	0	0	0	1	15
08:00	to	09:00	7	0	3	2	1	0	0	13	3	0	2	0	0	0	0	0	5	14	0	1	0	0	0	0	1	16
08:15	to	09:15	6	0	2	4	1	0	2	15	4	0	2	0	0	0	0	0	6	15	0	1	0	0	0	0	0	16
08:30	to	09:30	8	0	4	4	1	0	2	19	4	0	3	1	0	0	0	0	8	9	0	2	0	0	0	0	0	11
08:45	to	09:45	8	0	3	3	0	0	2	16	3	0	2	1	0	0	0	0	6	5	0	2	0	0	0	0	0	7
09:00	to	10:00	10	0	3	5	1	0	2	21	2	0	1	1	0	0	0	0	4	3	0	1	3	0	0	1	0	8

PM Hourly Summary

Time Period			Direction 1								Direction 2								Direction 3										
			Cars	Taxi	LGV	OGV1	OGV2	PSV	MC	Cycles	Total	Cars	Taxi	LGV	OGV1	OGV2	PSV	MC	Cycles	Total	Cars	Taxi	LGV	OGV1	OGV2	PSV	MC	Cycles	Total
16:00	to	17:00	15	0	10	4	0	0	0	0	29	8	0	1	2	0	0	0	0	11	8	0	2	0	0	0	0	1	11
16:15	to	17:15	12	0	11	2	0	0	0	0	25	9	0	1	2	0	0	1	0	13	8	0	2	0	0	0	2	1	13
16:30	to	17:30	11	0	10	0	0	0	0	0	21	7	0	2	1	0	0	1	0	11	9	0	3	0	0	0	2	1	15
16:45	to	17:45	11	0	7	0	0	0	0	0	18	9	0	2	0	0	0	1	2	14	8	0	3	0	0	0	2	1	14
17:00	to	18:00	7	0	7	1	0	0	0	0	15	12	0	3	0	0	0	2	2	19	8	0	3	0	0	0	2	0	13
17:15	to	18:15	4	0	4	1	0	0	0	0	9	10	0	3	0	0	0	1	2	16	9	0	4	0	0	0	0	0	13
17:30	to	18:30	6	0	3	1	0	0	0	0	10	13	0	2	0	0	0	1	2	18	12	0	3	0	0	0	0	0	15
17:45	to	18:45	7	0	3	1	0	0	0	0	11	12	0	2	0	0	0	1	0	15	11	0	3	0	0	0	0	0	14
18:00	to	19:00	7	0	1	0	0	0	0	0	8	10	0	1	0	0	0	0	0	11	12	0	3	0	0	0	0	0	15



SKY HIGH LTD - THE TRAFFIC SURVEY COMPANY

Job :
Client : Peter Bretts Associates
Location : Rollins Street/Lovelinch Close
Day : Thurs 09th July 2009
Weather : Fine
Peak Hour AM : 8:30 AM to 9:30 AM
Peak Hour PM : 4:15 PM to 5:15 PM

Choose Time Period

7:00 to 8:00 ▼

- = Total number by direction
- = Total number of inbound and outbound traffic flows

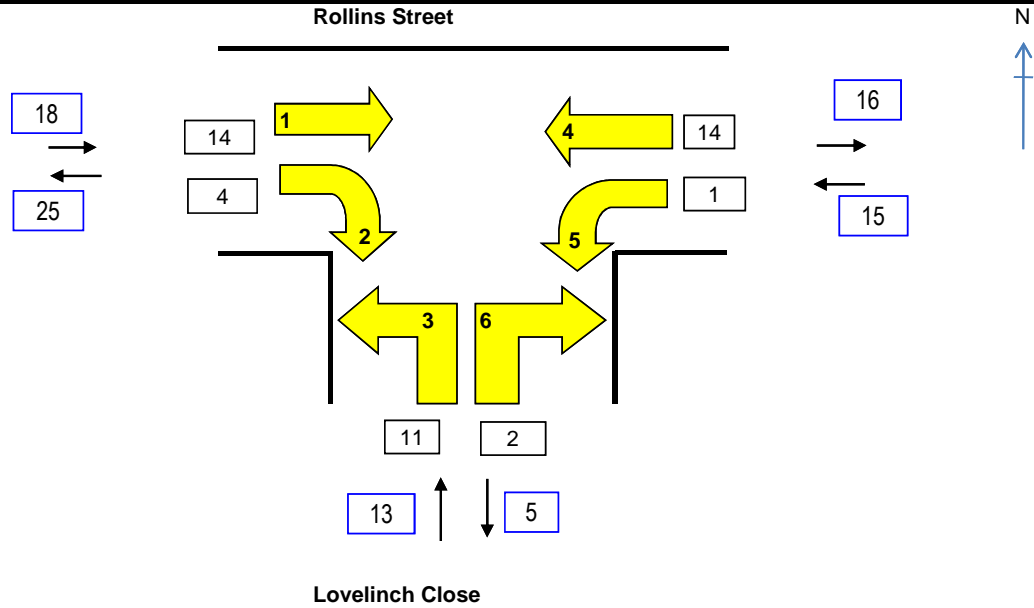



SKY HIGH LTD - THE TRAFFIC SURVEY COMPANY

AM 15 Minute Data Summary

Job :
Client : Peter Bretts Associates
Location : Ilderton Road/Surrey Canal Road
Day : Thurs 09th July 2009
Weather : Fine
Peak Hour AM 9:00 AM to 10:00 AM

Vehicle Class Summary

Cars	Taxi	LGV	OGV1	OGV2	PSV	MC	Cycles
43.8%	0.0%	20.4%	20.4%	15.2%	0.0%	0.0%	0.3%

Note : Gate Close at 17:15

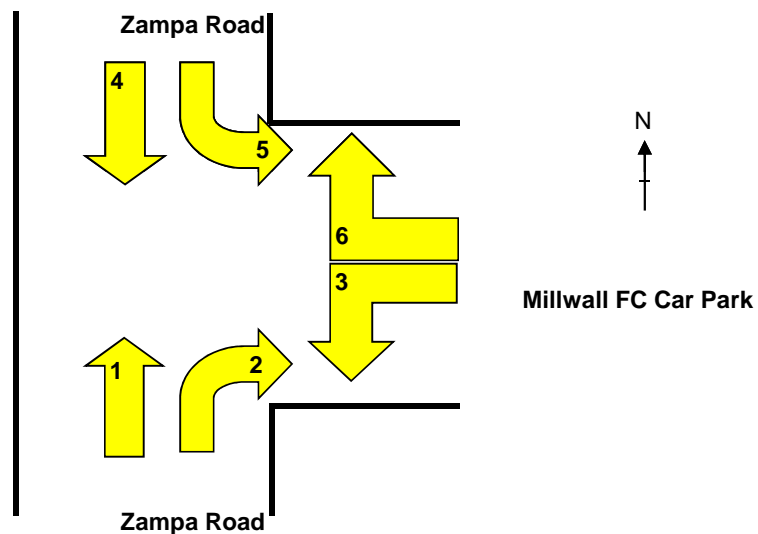

Time Period	Direction 1									Direction 2									Direction 3								
	Cars	Taxi	LGV	OGV1	OGV2	PSV	MC	Cycles	Total	Cars	Taxi	LGV	OGV1	OGV2	PSV	MC	Cycles	Total	Cars	Taxi	LGV	OGV1	OGV2	PSV	MC	Cycles	Total
07:00 to 07:15	2		3	5	2				12									0									0
07:15 to 07:30	6		2	3	1				12									0									0
07:30 to 07:45	4		3	5	2				14									0	1			1					2
07:45 to 08:00	3		1	1					5	2		1						3	1			1					2
08:00 to 08:15	8		5	3	1				17	1								1									0
08:15 to 08:30	7		4	2	2				15	1								1									0
08:30 to 08:45	5		3	4	1				13									0	1								1
08:45 to 09:00	6		2	1	3				12			1						1			1						1
09:00 to 09:15	8		5	4	4				21	1								1			1						1
09:15 to 09:30	7		4	2	2				15	2								2	2								2
09:30 to 09:45	7		4	4	4				19	2								2									0
09:45 to 10:00	9		9	4	6				28	4		1	1	1				7	2		1						3
Survey Total	72	0	45	38	28	0	0	0	183	13	0	2	2	1	0	0	0	18	7	0	3	2	0	0	0	0	12

PM 15 Minute Data Summary

Job :
 Client : Peter Bretts Associates
 Location : Ilderton Road/Surrey Canal Road
 Day : Thurs 09th July 2009
 Weather : Fine
 Peak Hour PM 4:00 PM to 5:00 PM

Vehicle Class Summary							
Cars	MC	LGV	OGV	OGV	PSV	MC	Cycle
67.6%	0.0%	15.4%	9.5%	2.2%	2.2%	3.0%	0.3%

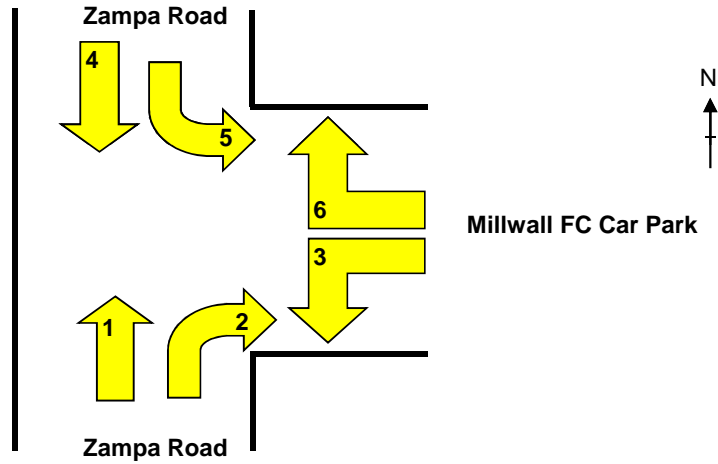

Time Period	Direction 1									Direction 2									Direction 3								
	Cars	Taxi	LGV	OGV1	OGV2	PSV	MC	Cycles	Total	Cars	Taxi	LGV	OGV1	OGV2	PSV	MC	Cycles	Total	Cars	Taxi	LGV	OGV1	OGV2	PSV	MC	Cycles	Total
16:00 to 16:15	4		2	1	2				9	5								5	4		1			2			7
16:15 to 16:30	4		2	1	1				8	1								1	3				2			5	
16:30 to 16:45	6		1	2	0		1		10	1						1		2	8				1			9	
16:45 to 17:00	5		2	1	0				8	1	1							1	8		1					9	
17:00 to 17:15	4		2	1	0				7	2								2			1			3		4	
17:15 to 17:30	5		1	1	0				7	1								1								0	
17:30 to 17:45	5		1	1	1		1		9	1								1								0	
17:45 to 18:00	4		2	1	1				8	4								4								0	
18:00 to 18:15	8		1	1	0				10	1								1								0	
18:15 to 18:30	6		1	1	0		1		9	2								2								0	
18:30 to 18:45	6		1	2	1				10	1								1								0	
18:45 to 19:00	4		2	1	1				8	1								1								0	
Survey Total	61	0	18	14	7	0	3	0	103	21	0	0	0	0	0	1	0	22	23	0	3	0	0	8	0	0	34

AM Hourly Summary

Job :
Client : Peter Bretts Associates
Location : Ilderton Road/Surrey Canal Road
Day : Thurs 09th July 2009
Weather : Fine
Peak Hour AM 9:00 AM to 10:00 AM
Peak Hour PM 4:00 PM to 5:00PM

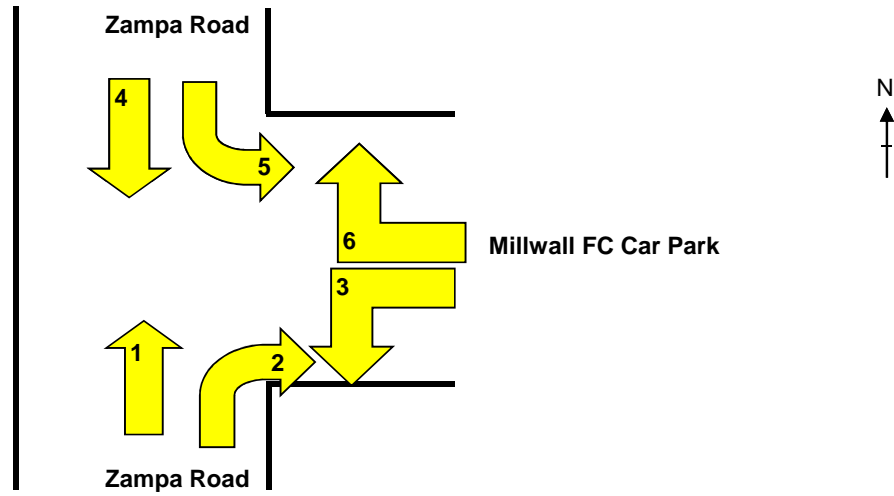

			Direction 1								Direction 2								Direction 3										
Time Period			Cars	Taxi	LGV	OGV1	OGV2	PSV	MC	Cycles	Total	Cars	Taxi	LGV	OGV1	OGV2	PSV	MC	Cycles	Total	Cars	Taxi	LGV	OGV1	OGV2	PSV	MC	Cycles	Total
07:00	to	08:00	15	0	9	14	5	0	0	0	43	2	0	0	1	0	0	0	0	3	2	0	0	2	0	0	0	0	4
07:15	to	08:15	16	0	11	12	4	0	0	0	43	3	0	0	1	0	0	0	0	4	2	0	0	2	0	0	0	0	4
07:30	to	08:30	17	0	13	11	5	0	0	0	46	4	0	0	1	0	0	0	0	5	2	0	0	2	0	0	0	0	4
07:45	to	08:45	20	0	13	10	4	0	0	0	47	4	0	0	1	0	0	0	0	5	2	0	0	1	0	0	0	0	3
08:00	to	09:00	23	0	14	10	7	0	0	0	54	2	0	1	0	0	0	0	0	3	1	0	1	0	0	0	0	0	2
08:15	to	09:15	23	0	14	11	10	0	0	0	58	2	0	1	0	0	0	0	0	3	1	0	2	0	0	0	0	0	3
08:30	to	09:30	23	0	14	11	10	0	0	0	58	3	0	1	0	0	0	0	0	4	3	0	2	0	0	0	0	0	5
08:45	to	09:45	25	0	15	11	13	0	0	0	64	5	0	1	0	0	0	0	0	6	2	0	2	0	0	0	0	0	4
09:00	to	10:00	28	0	22	14	16	0	0	0	80	9	0	1	1	1	0	0	0	12	4	0	2	0	0	0	0	0	6





SKY HIGH LTD - THE TRAFFIC SURVEY COMPANY

Job :
Client : Peter Bretts Associates
Location : Ilderton Road/Surrey Canal Road
Day : Thurs 09th July 2009
Weather : Fine
Peak Hour AM 7:45 AM to 8:45 AM
Peak Hour PM 5:45 PM to 6:45 PM

Choose Time Period

7:00 to 8:00 ▼

 = Total number by direction

 = Total number of inbound and outbound traffic flows

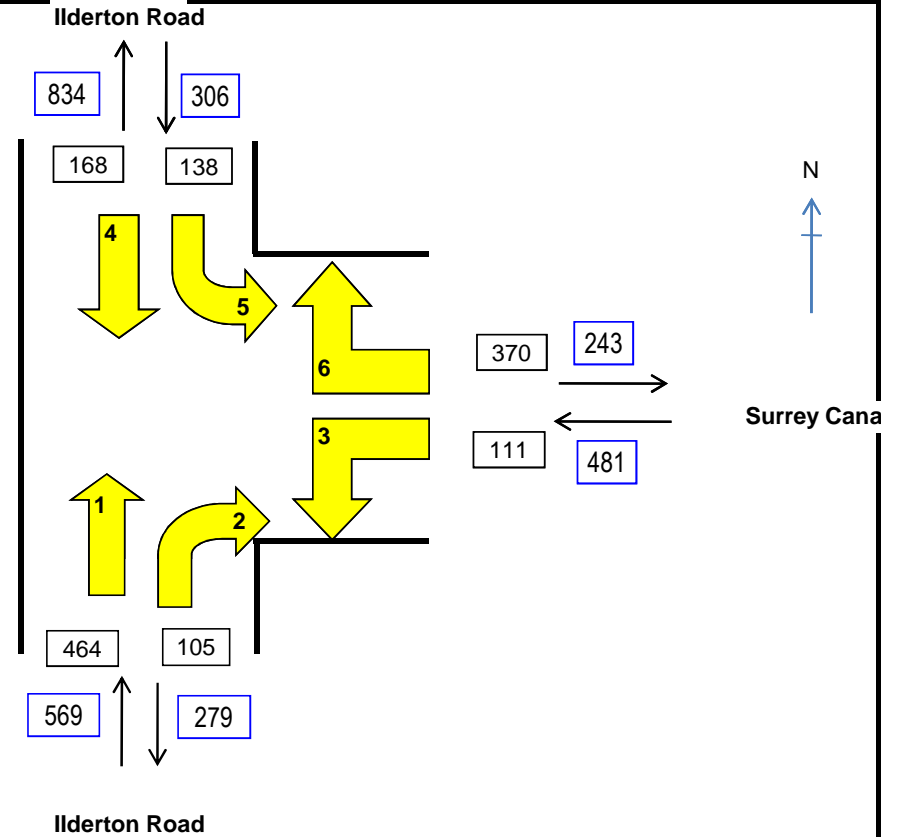



SKY HIGH LTD - THE TRAFFIC SURVEY COMPANY

AM 15 Minute Data Summary

Job :
Client : Peter Bretts Associates
Location : Ilderton Road/Ablett Street
Day : Thurs 09th July 2009
Weather : Fine
Peak Hour AM 7:00 AM to 8:00 AM

Vehicle Class Summary

Cars	Taxi	LGV	OGV1	OGV2	PSV	MC	Cycles
61.1%	1.0%	20.4%	6.8%	2.7%	2.1%	2.7%	3.1%

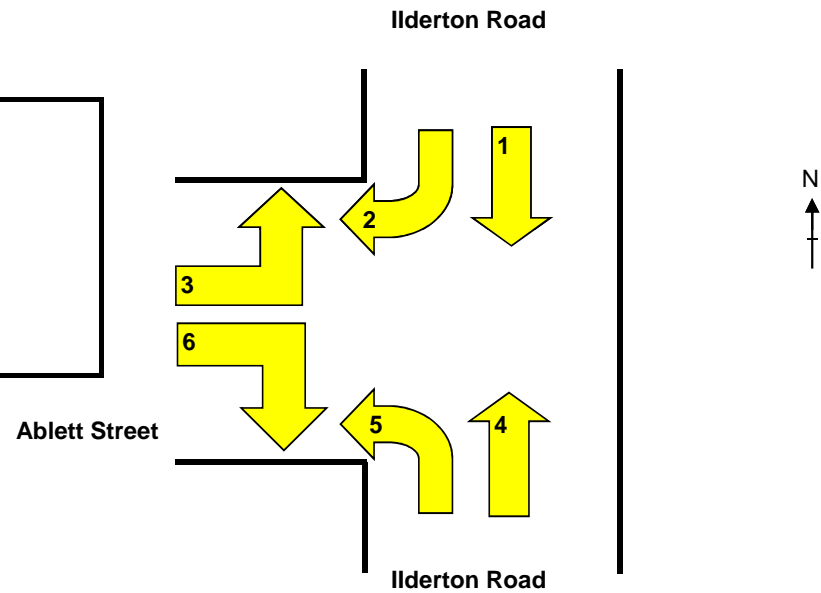

Time Period	Direction 1									Direction 2									Direction 3								
	Cars	Taxi	LGV	OGV1	OGV2	PSV	MC	Cycles	Total	Cars	Taxi	LGV	OGV1	OGV2	PSV	MC	Cycles	Total	Cars	Taxi	LGV	OGV1	OGV2	PSV	MC	Cycles	Total
07:00 to 07:15	43	0	14	6	2	2	3	0	70	6	0	0	0	0	0	0	0	6	8	0	0	0	0	0	0	0	8
07:15 to 07:30	44	0	14	5	0	1	0	2	66	0	0	1	0	0	0	0	0	1	6	0	1	1	0	0	1	0	9
07:30 to 07:45	31	2	13	6	2	2	3	3	62	4	0	2	0	0	0	1	0	7	5	0	1	0	0	0	0	0	6
07:45 to 08:00	48	0	15	10	4	2	0	4	83	5	0	6	0	0	0	0	0	11	7	0	1	0	0	0	0	0	8
08:00 to 08:15	38	1	16	1	4	1	3	0	64	0	0	2	0	0	0	0	0	2	12	0	0	0	0	0	0	0	12
08:15 to 08:30	40	0	13	4	2	4	1	2	66	3	0	0	0	0	0	0	0	3	12	0	4	0	0	0	0	0	16
08:30 to 08:45	49	1	15	8	3	3	2	0	81	5	0	1	0	0	0	0	0	6	7	1	3	0	0	0	0	0	11
08:45 to 09:00	69	1	21	8	4	4	1	1	109	3	0	0	0	0	0	0	0	3	10	1	2	0	0	0	0	0	13
09:00 to 09:15	53	1	16	5	3	5	1	1	85	7	0	0	0	0	0	0	0	7	8	1	4	1	0	0	0	0	14
09:15 to 09:30	46	2	19	9	1	5	0	2	84	7	0	2	0	0	0	0	0	9	4	0	0	0	0	0	0	0	4
09:30 to 09:45	51	3	13	15	0	4	1	0	87	7	0	1	0	0	0	0	0	8	10	0	1	0	0	0	0	0	11
09:45 to 10:00	61	1	26	10	8	6	5	1	118	8	0	2	0	0	0	0	0	10	7	0	2	0	0	0	0	0	9
Survey Total	573	12	195	87	33	39	20	16	975	55	0	17	0	0	0	1	0	73	96	3	19	2	0	0	1	0	121

Time Period	Direction 4									Direction 5									Direction 6								
	Cars	Taxi	LGV	OGV1	OGV2	PSV	MC	Cycles	Total	Cars	Taxi	LGV	OGV1	OGV2	PSV	MC	Cycles	Total	Cars	Taxi	LGV	OGV1	OGV2	PSV	MC	Cycles	Total
07:00 to 07:15	110	1	56	16	7	1	9	2	202	2	0	0	0	0	0	0	0	2	0	0	0	0	0	0	0	0	0
07:15 to 07:30	100	0	44	7	5	4	6	7	173	1	0	2	0	0	0	0	0	3	2	0	0	0	0	0	0	0	2
07:30 to 07:45	91	1	34	9	1	1	3	3	143	0	0	0	0	0	0	0	0	0	0	0	0	0	0	0	0	0	0
07:45 to 08:00	100	2	33	11	5	3	3	5	162	0	0	0	0	0	0	0	0	0	0	0	0	0	0	0	0	0	0
08:00 to 08:15	97	0	26	8	4	1	7	9	152	1	0	0	0	0	0	0	0	1	0	0	0	0	0	0	0	0	0
08:15 to 08:30	97	1	17	5	3	3	4	12	142	0	0	2	0	0	0	0	0	2	1	0	1	0	0	0	0	0	2
08:30 to 08:45	83	0	20	6	1	1	9	12	132	0	0	2	0	0	0	0	0	2	0	2	0	0	0	0	0	0	2
08:45 to 09:00	72	2	28	9	2	2	6	9	130	2	0	1	0	0	0	0	0	3	2	0	0	0	0	0	0	0	2
09:00 to 09:15	89	1	23	8	3	1	4	3	132	0	0	0	0	0	0	0	0	0	0	0	2	0	0	1	0	0	3
09:15 to 09:30	86	1	28	11	1	1	1	8	137	0	0	0	0	0	0	0	0	0	0	0	0	0	0	0	0	0	0
09:30 to 09:45	78	1	33	11	12	1	1	3	140	1	0	1	0	0	0	0	0	2	1	0	0	0	0	0	0	0	1
09:45 to 10:00	61	3	19	10	3	3	5	2	106	0	0	0	0	0	0	0	0	0	2	0	0	0	0	0	0	0	2
Survey Total	1064	13	361	111	47	22	58	75	1751	7	0	8	0	0	0	0	0	15	8	2	3	0	0	1	0	0	14

PM 15 Minute Data Summary

Job :
 Client : Peter Bretts Associates
 Location : Ilderton Road/Ablett Street
 Day : Thurs 09th July 2009
 Weather : Fine
 Peak Hour PM 6:00 PM to 7:00 PM

Vehicle Class Summary							
Cars	MC	LGV	OGV	OGV	PSV	MC	Cycle
69.4%	1.8%	16.4%	3.6%	0.4%	1.8%	4.1%	2.4%

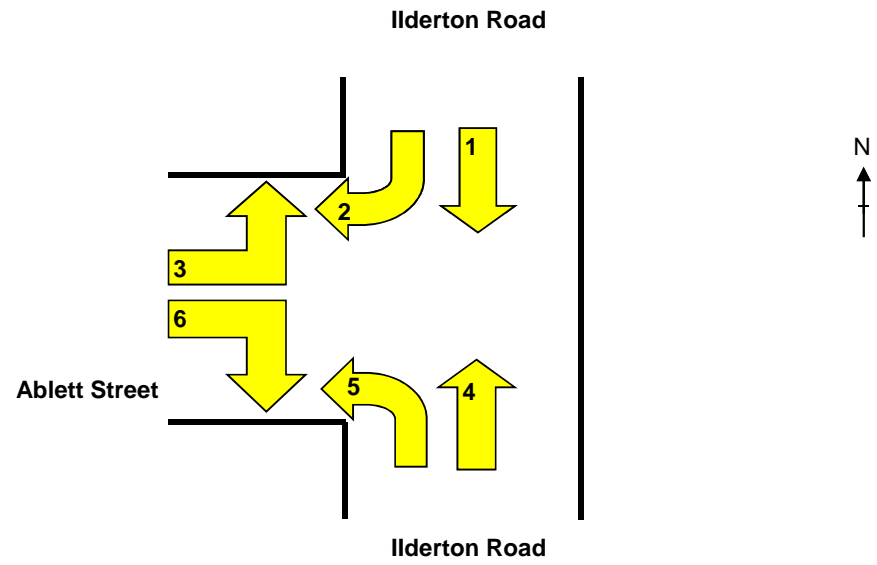

Time Period	Direction 1									Direction 2									Direction 3								
	Cars	Taxi	LGV	OGV1	OGV2	PSV	MC	Cycles	Total	Cars	Taxi	LGV	OGV1	OGV2	PSV	MC	Cycles	Total	Cars	Taxi	LGV	OGV1	OGV2	PSV	MC	Cycles	Total
16:00 to 16:15	79	0	50	7	1	0	8	2	147	4	0	0	0	0	0	2	0	6	4	0	4	0	0	0	1	0	9
16:15 to 16:30	95	3	43	12	2	3	4	4	166	8	0	1	0	0	0	1	0	10	12	0	0	0	0	0	1	0	13
16:30 to 16:45	69	2	29	9	1	0	7	1	118	5	0	1	0	0	0	0	0	6	6	0	2	0	0	0	0	0	8
16:45 to 17:00	39	2	12	3	1	1	3	2	63	3	0	1	0	0	0	0	0	4	5	0	3	0	0	0	0	0	8
17:00 to 17:15	75	4	20	3	0	1	5	5	113	1	0	0	0	0	0	0	0	1	5	1	2	0	0	0	0	0	8
17:15 to 17:30	61	2	20	3	1	0	8	2	97	7	1	3	0	0	0	0	0	11	4	0	0	0	0	0	0	0	4
17:30 to 17:45	91	4	15	10	0	3	3	0	126	9	0	0	0	0	0	0	0	9	6	1	1	0	0	0	0	0	8
17:45 to 18:00	90	4	20	7	0	2	6	3	132	7	0	0	0	0	0	1	0	8	8	0	0	1	0	0	0	0	9
18:00 to 18:15	96	2	31	5	0	1	3	3	141	8	1	1	0	0	0	0	0	10	9	0	0	1	0	0	0	0	10
18:15 to 18:30	46	4	8	2	0	3	7	3	73	9	0	0	0	0	0	0	0	9	7	0	0	0	0	0	0	0	7
18:30 to 18:45	114	1	18	4	0	3	3	8	151	9	0	1	0	0	0	0	0	10	12	0	0	0	0	0	0	0	12
18:45 to 19:00	91	3	17	2	0	1	9	11	134	8	0	0	1	0	1	0	0	10	2	0	0	0	0	0	1	0	3
Survey Total	946	31	283	67	6	18	66	44	1461	78	2	8	1	0	1	4	0	94	80	2	12	2	0	0	3	0	99

AM Hourly Summary

Job :
Client : Peter Bretts Associates
Location : Ilderton Road/Ablett Street
Day : Thurs 09th July 2009
Weather : Fine
Peak Hour AM 7:00 AM to 8:00 AM
Peak Hour PM 6:00 PM to 5:00PM

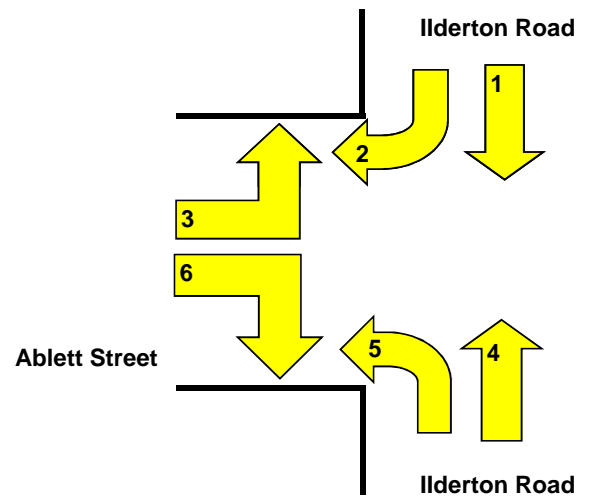

Time Period			Direction 1								Direction 2								Direction 3										
			Cars	Taxi	LGV	OGV1	OGV2	PSV	MC	Cycles	Total	Cars	Taxi	LGV	OGV1	OGV2	PSV	MC	Cycles	Total	Cars	Taxi	LGV	OGV1	OGV2	PSV	MC	Cycles	Total
07:00	to	08:00	166	2	56	27	8	7	6	9	281	15	0	9	0	0	0	1	0	25	26	0	3	1	0	0	1	0	31
07:15	to	08:15	161	3	58	22	10	6	6	9	275	9	0	11	0	0	0	1	0	21	30	0	3	1	0	0	1	0	35
07:30	to	08:30	157	3	57	21	12	9	7	9	275	12	0	10	0	0	0	1	0	23	36	0	6	0	0	0	0	0	42
07:45	to	08:45	175	2	59	23	13	10	6	6	294	13	0	9	0	0	0	0	0	22	38	1	8	0	0	0	0	0	47
08:00	to	09:00	196	3	65	21	13	12	7	3	320	11	0	3	0	0	0	0	0	14	41	2	9	0	0	0	0	0	52
08:15	to	09:15	211	3	65	25	12	16	5	4	341	18	0	1	0	0	0	0	0	19	37	3	13	1	0	0	0	0	54
08:30	to	09:30	217	5	71	30	11	17	4	4	359	22	0	3	0	0	0	0	0	25	29	3	9	1	0	0	0	0	42
08:45	to	09:45	219	7	69	37	8	18	3	4	365	24	0	3	0	0	0	0	0	27	32	2	7	1	0	0	0	0	42
09:00	to	10:00	211	7	74	39	12	20	7	4	374	29	0	5	0	0	0	0	0	34	29	1	7	1	0	0	0	0	38

Time Period			Direction 4								Direction 5								Direction 6										
			Cars	Taxi	LGV	OGV1	OGV2	PSV	MC	Cycles	Total	Cars	Taxi	LGV	OGV1	OGV2	PSV	MC	Cycles	Total	Cars	Taxi	LGV	OGV1	OGV2	PSV	MC	Cycles	Total
07:00	to	08:00	401	4	167	43	18	9	21	17	680	3	0	2	0	0	0	0	0	5	2	0	0	0	0	0	0	0	2
07:15	to	08:15	388	3	137	35	15	9	19	24	630	2	0	2	0	0	0	0	0	4	2	0	0	0	0	0	0	0	2
07:30	to	08:30	385	4	110	33	13	8	17	29	599	1	0	2	0	0	0	0	0	3	1	0	1	0	0	0	0	0	2
07:45	to	08:45	377	3	96	30	13	8	23	38	588	1	0	4	0	0	0	0	0	5	1	2	1	0	0	0	0	0	4
08:00	to	09:00	349	3	91	28	10	7	26	42	556	3	0	5	0	0	0	0	0	8	3	2	1	0	0	0	0	0	6
08:15	to	09:15	341	4	88	28	9	7	23	36	536	2	0	5	0	0	0	0	0	7	3	2	3	0	0	1	0	0	9
08:30	to	09:30	330	4	99	34	7	5	20	32	531	2	0	3	0	0	0	0	0	5	2	2	2	0	0	1	0	0	7
08:45	to	09:45	325	5	112	39	18	5	12	23	539	3	0	2	0	0	0	0	0	5	3	0	2	0	0	1	0	0	6
09:00	to	10:00	314	6	103	40	19	6	11	16	515	1	0	1	0	0	0	0	0	2	3	0	2	0	0	1	0	0	6

PM Hourly Summary

Time Period			Direction 1								Direction 2								Direction 3										
			Cars	Taxi	LGV	OGV1	OGV2	PSV	MC	Cycles	Total	Cars	Taxi	LGV	OGV1	OGV2	PSV	MC	Cycles	Total	Cars	Taxi	LGV	OGV1	OGV2	PSV	MC	Cycles	Total
16:00	to	17:00	282	7	134	31	5	4	22	9	494	20	0	3	0	0	0	3	0	26	27	0	9	0	0	0	2	0	38
16:15	to	17:15	278	11	104	27	4	5	19	12	460	17	0	3	0	0	0	1	0	21	28	1	7	0	0	0	1	0	37
16:30	to	17:30	244	10	81	18	3	2	23	10	391	16	1	5	0	0	0	0	0	22	20	1	7	0	0	0	0	0	28
16:45	to	17:45	266	12	67	19	2	5	19	9	399	20	1	4	0	0	0	0	0	25	20	2	6	0	0	0	0	0	28
17:00	to	18:00	317	14	75	23	1	6	22	10	468	24	1	3	0	0	0	1	0	29	23	2	3	1	0	0	0	0	29
17:15	to	18:15	338	12	86	25	1	6	20	8	496	31	2	4	0	0	0	1	0	38	27	1	1	2	0	0	0	0	31
17:30	to	18:30	323	14	74	24	0	9	19	9	472	33	1	1	0	0	0	1	0	36	30	1	1	2	0	0	0	0	34
17:45	to	18:45	346	11	77	18	0	9	19	17	497	33	1	2	0	0	0	1	0	37	36	0	0	2	0	0	0	0	38
18:00	to	19:00	347	10	74	13	0	8	22	25	499	34	1	2	1	0	1	0	0	39	30	0	0	1	0	0	1	0	32





SKY HIGH LTD - THE TRAFFIC SURVEY COMPANY

Job :
Client : Peter Bretts Associates
Location : Ilderton Road/Ablett Street
Day : Thurs 09th July 2009
Weather : Fine
Peak Hour AM : 7:00 AM to 8:00 AM
Peak Hour PM : 6:00 PM to 7:00 PM

Choose Time Period

7:00 to 8:00 ▼

 = Total number by direction

 = Total number of inbound and outbound traffic flows

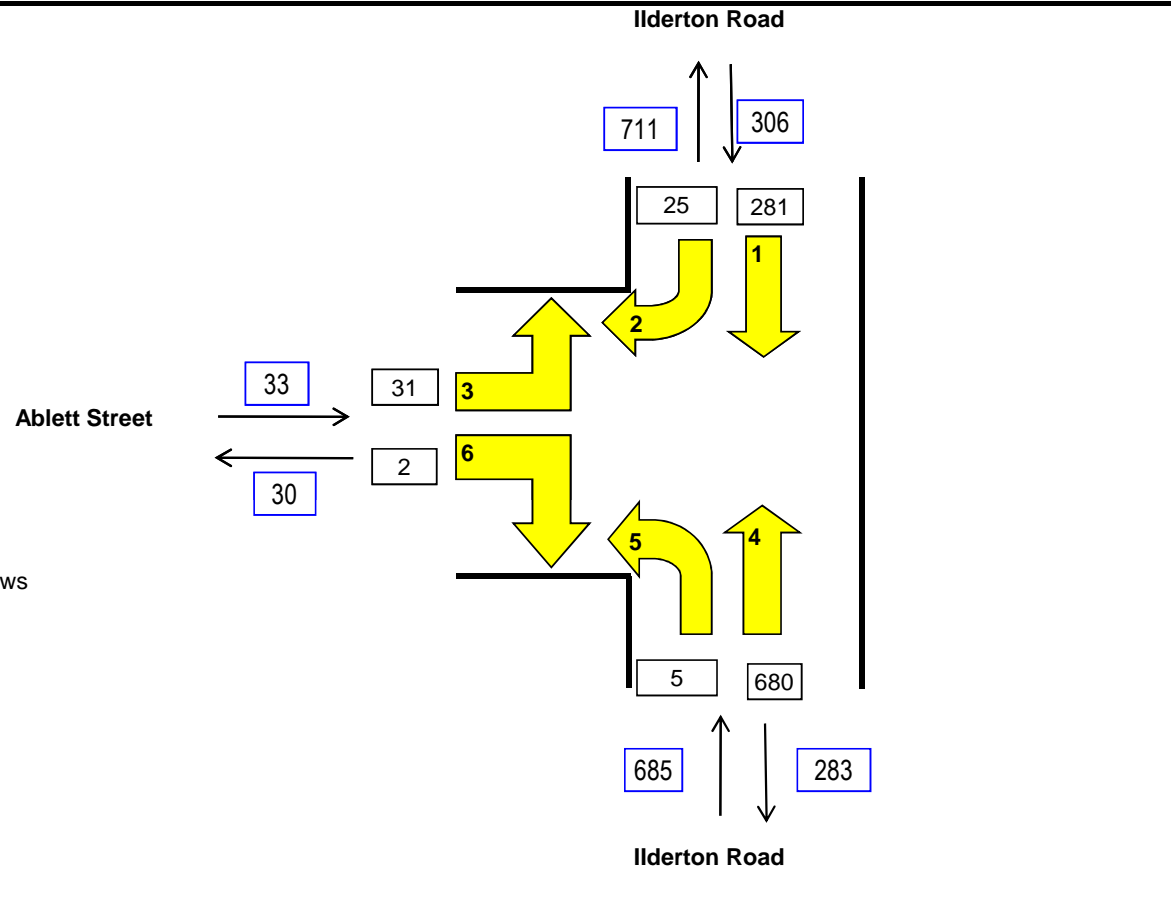



SKY HIGH LTD - THE TRAFFIC SURVEY COMPANY

AM 15 Minute Data Summary

Job :
Client : Peter Bretts Associates
Location : Silwood Street/Bolina Road
Day : Thurs 09th July 2009
Weather : Fine
Peak Hour AM 7:45 AM to 8:45 AM

Vehicle Class Summary

Cats	Taxi	LGV	OGV1	OGV2	PSV	MC	Cycles
48.8%	0.0%	26.1%	12.4%	3.1%	0.0%	2.7%	6.9%

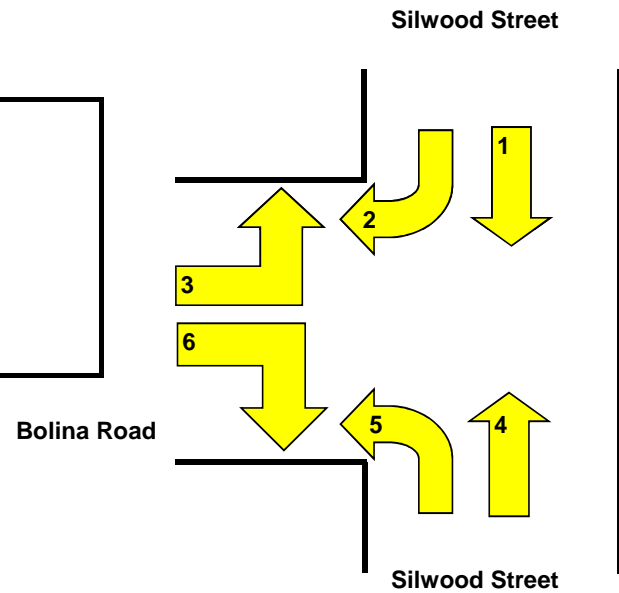

Time Period	Direction 1									Direction 2									Direction 3								
	Cars	Taxi	LGV	OGV1	OGV2	PSV	MC	Cycles	Total	Cars	Taxi	LGV	OGV1	OGV2	PSV	MC	Cycles	Total	Cars	Taxi	LGV	OGV1	OGV2	PSV	MC	Cycles	Total
07:00 to 07:15	1	0	2	2	0	0	1	0	6	1	0	0	0	0	0	0	0	1	1	0	0	0	0	0	0	0	1
07:15 to 07:30	7	0	5	0	0	0	1	0	13	0	0	1	1	0	0	0	1	3	2	0	0	0	0	0	0	0	2
07:30 to 07:45	3	0	3	2	0	0	1	1	10	1	0	2	1	0	0	0	0	4	0	0	0	1	0	0	0	0	1
07:45 to 08:00	4	0	2	0	0	0	2	1	9	0	0	0	1	0	0	0	0	1	0	0	2	1	0	0	0	0	3
08:00 to 08:15	4	0	0	1	0	0	0	0	5	1	0	1	0	0	0	0	0	2	1	0	2	0	0	0	0	0	3
08:15 to 08:30	3	0	0	1	0	0	0	1	5	2	0	1	0	0	0	0	1	4	8	0	0	0	0	0	0	0	8
08:30 to 08:45	3	0	1	0	0	0	1	1	6	3	0	0	1	0	0	0	1	5	4	0	1	1	0	0	0	0	6
08:45 to 09:00	4	0	1	1	0	0	0	0	6	1	0	0	0	0	0	0	0	1	0	0	0	0	0	0	1	1	2
09:00 to 09:15	1	0	1	0	1	0	0	1	4	1	0	1	1	0	0	0	0	3	3	0	0	0	0	0	0	0	3
09:15 to 09:30	3	0	0	2	0	0	0	0	5	2	0	0	0	0	0	0	0	2	0	0	0	0	0	0	0	0	0
09:30 to 09:45	2	0	1	1	1	0	0	0	5	4	0	2	0	0	0	0	0	6	4	0	1	0	0	0	0	0	5
09:45 to 10:00	2	0	2	0	1	0	0	0	5	1	0	2	0	0	0	0	0	3	2	0	0	0	0	0	0	0	2
Survey Total	37	0	18	10	3	0	6	5	79	17	0	10	5	0	0	0	3	35	25	0	6	3	0	0	1	1	36

Time Period	Direction 4									Direction 5									Direction 6									
	Cars	Taxi	LGV	OGV1	OGV2	PSV	MC	Cycles	Total	Cars	Taxi	LGV	OGV1	OGV2	PSV	MC	Cycles	Total	Cars	Taxi	LGV	OGV1	OGV2	PSV	MC	Cycles	Total	
07:00 to 07:15	0	0	4	0	1	0	0	0	5	0	0	0	0	0	0	0	0	0	0	0	0	0	0	0	0	0	0	0
07:15 to 07:30	3	0	2	3	0	0	0	0	8	1	0	0	0	0	0	0	0	1	1	0	0	0	0	0	0	0	1	2
07:30 to 07:45	3	0	0	1	2	0	0	0	6	2	0	1	0	0	0	0	0	3	1	0	2	0	0	0	0	0	0	3
07:45 to 08:00	2	0	6	0	1	0	0	2	11	1	0	2	0	0	0	0	0	3	1	0	0	0	0	0	0	0	0	1
08:00 to 08:15	1	0	7	5	0	0	0	0	13	2	0	0	0	0	0	0	0	2	1	0	0	0	0	0	0	0	0	1
08:15 to 08:30	3	0	4	1	0	0	0	1	9	5	0	0	0	0	0	0	0	5	2	0	1	0	0	0	0	0	0	3
08:30 to 08:45	5	0	2	0	0	0	0	2	9	2	0	1	0	0	0	0	0	3	0	0	0	0	0	0	0	0	0	0
08:45 to 09:00	1	0	0	1	0	0	0	2	4	2	0	0	1	0	0	0	0	3	3	0	0	0	0	0	0	0	0	3
09:00 to 09:15	1	0	0	1	0	0	0	0	2	3	0	1	1	0	0	0	0	5	0	0	1	1	0	0	0	0	0	2
09:15 to 09:30	3	0	4	0	1	0	0	0	8	3	0	0	0	0	0	0	0	3	1	0	1	0	0	0	0	0	0	2
09:30 to 09:45	1	0	1	2	1	0	0	1	6	1	0	0	0	0	0	0	0	1	0	0	0	0	0	0	0	0	0	0
09:45 to 10:00	4	0	2	0	0	0	0	2	8	1	0	0	0	0	0	1	0	2	3	0	0	1	0	0	0	0	0	4
Survey Total	27	0	32	14	6	0	0	10	89	23	0	5	2	0	0	1	0	31	13	0	5	2	0	0	0	1	21	

PM 15 Minute Data Summary

Job :
 Client : Peter Bretts Associates
 Location : Silwood Street/Bolina Road
 Day : Thurs 09th July 2009
 Weather : Fine
 Peak Hour PM 4:00 PM to 5:00 PM

Vehicle Class Summary							
Cars	MC	LGV	OGV	OGV	PSV	MC	Cycle
66.0%	0.8%	18.4%	5.6%	0.8%	0.0%	1.9%	6.4%

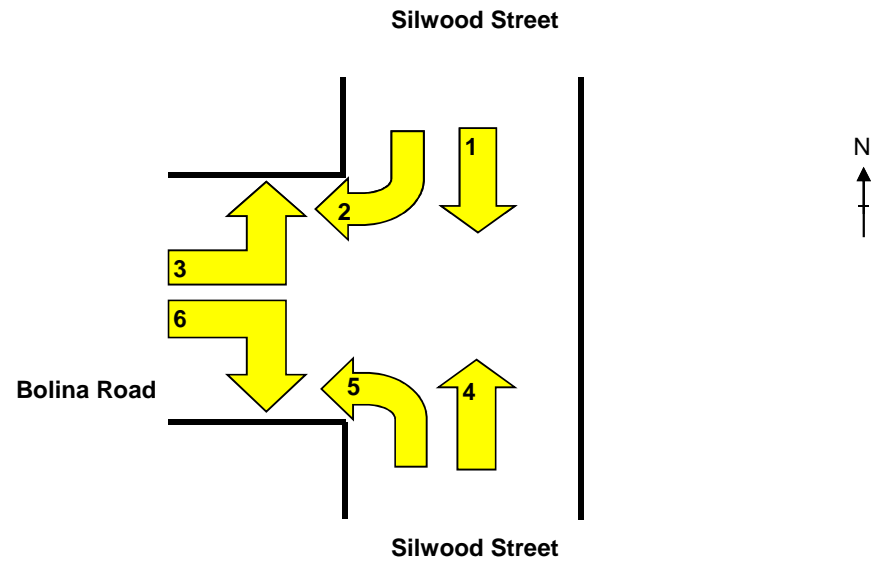

Time Period	Direction 1									Direction 2									Direction 3									
	Cars	Taxi	LGV	OGV1	OGV2	PSV	MC	Cycles	Total	Cars	Taxi	LGV	OGV1	OGV2	PSV	MC	Cycles	Total	Cars	Taxi	LGV	OGV1	OGV2	PSV	MC	Cycles	Total	
16:00 to 16:15	2	0	0	3	0	0	0	0	5	4	0	1	0	0	0	0	0	5	1	0	2	2	0	0	0	0	0	5
16:15 to 16:30	2	0	0	0	0	0	0	0	2	7	0	1	1	0	0	0	0	9	4	0	1	0	0	0	0	0	0	5
16:30 to 16:45	2	0	1	0	1	0	0	1	5	4	0	1	1	0	0	0	0	6	2	0	2	1	0	0	0	0	0	5
16:45 to 17:00	4	0	2	0	0	0	0	0	6	4	0	4	0	0	0	0	0	8	7	0	1	0	0	0	0	0	0	8
17:00 to 17:15	3	0	2	0	0	0	0	2	7	2	0	0	0	0	0	0	0	2	6	0	0	0	0	0	0	0	0	6
17:15 to 17:30	2	0	3	0	0	0	0	0	5	5	0	2	0	0	0	0	0	7	1	0	0	0	0	0	0	0	0	1
17:30 to 17:45	2	0	1	2	0	0	0	0	5	4	0	1	0	0	0	1	0	6	3	0	1	1	0	0	0	1	0	6
17:45 to 18:00	5	0	0	0	1	0	0	1	7	3	0	0	0	0	0	0	0	3	2	0	0	0	0	0	0	1	0	3
18:00 to 18:15	1	0	2	0	0	0	0	3	6	1	0	3	0	0	0	0	0	4	5	0	0	0	0	0	0	1	0	6
18:15 to 18:30	3	0	2	0	0	0	0	1	6	3	0	0	0	0	0	0	0	3	1	0	1	0	0	0	0	0	0	2
18:30 to 18:45	5	0	0	0	0	0	0	1	6	3	0	0	0	0	0	0	1	4	4	0	0	0	0	0	0	0	0	4
18:45 to 19:00	3	0	0	0	0	0	0	1	4	0	0	0	0	0	0	0	0	0	1	0	0	1	0	0	0	1	0	3
Survey Total	34	0	13	5	2	0	0	10	64	40	0	13	2	0	0	1	1	57	37	0	8	5	0	0	0	4	0	54

Time Period	Direction 4									Direction 5									Direction 6								
	Cars	Taxi	LGV	OGV1	OGV2	PSV	MC	Cycles	Total	Cars	Taxi	LGV	OGV1	OGV2	PSV	MC	Cycles	Total	Cars	Taxi	LGV	OGV1	OGV2	PSV	MC	Cycles	Total
16:00 to 16:15	8	2	1	2	0	0	0	0	13	2	0	1	0	0	0	0	0	3	0	0	0	0	0	0	0	0	0
16:15 to 16:30	7	0	1	0	1	0	0	0	9	2	0	1	0	0	0	0	0	3	2	0	0	0	0	0	0	0	2
16:30 to 16:45	7	0	3	1	0	0	0	0	11	2	0	1	0	0	0	0	0	3	3	0	1	0	0	0	0	0	4
16:45 to 17:00	8	0	5	0	0	0	0	0	13	3	0	0	0	0	0	0	0	3	3	1	0	0	0	0	0	0	4
17:00 to 17:15	5	0	3	0	0	0	1	0	9	2	0	0	0	0	0	0	0	2	1	0	0	0	0	0	1	0	2
17:15 to 17:30	4	0	1	0	0	0	1	0	6	2	0	1	0	0	0	1	1	5	0	0	0	0	0	0	0	0	0
17:30 to 17:45	4	0	2	0	0	0	0	3	9	1	0	0	0	0	0	0	0	1	2	0	0	0	0	0	0	0	2
17:45 to 18:00	12	0	6	3	0	0	1	0	22	3	0	0	0	0	0	0	0	3	3	0	1	0	0	0	0	0	4
18:00 to 18:15	5	0	1	1	0	0	0	0	7	3	0	1	0	0	0	0	0	4	1	0	0	0	0	0	0	0	1
18:15 to 18:30	8	0	0	0	0	0	1	1	10	2	0	0	0	0	0	0	0	2	1	0	0	0	0	0	0	2	3
18:30 to 18:45	7	0	2	1	0	0	0	0	10	4	0	0	0	0	0	0	0	4	3	0	0	0	0	0	0	0	3
18:45 to 19:00	4	0	0	0	0	0	0	1	5	0	0	0	0	0	0	0	0	0	2	0	0	0	0	0	0	0	2
Survey Total	79	2	25	8	1	0	4	5	124	26	0	5	0	0	0	1	1	33	21	1	2	0	0	0	1	2	27

AM Hourly Summary

Job :
Client : Peter Bretts Associates
Location : Silwood Street/Bolina Road
Day : Thurs 09th July 2009
Weather : Fine
Peak Hour AM 7:45 AM to 8:45 AM
Peak Hour PM 4:00 PM to 5:00PM

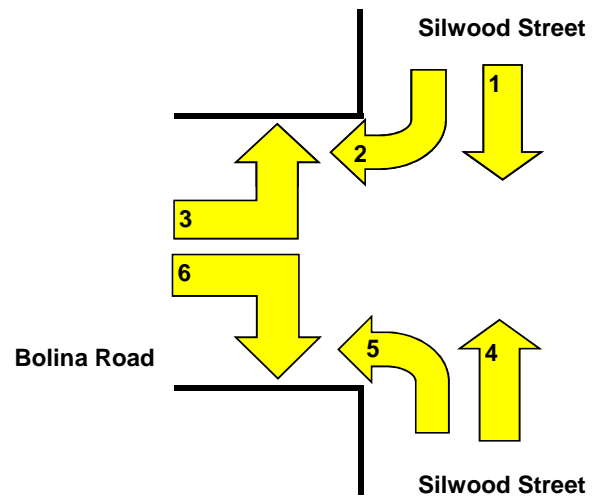

Time Period			Direction 1								Direction 2								Direction 3										
			Cars	Taxi	LGV	OGV1	OGV2	PSV	MC	Cycles	Total	Cars	Taxi	LGV	OGV1	OGV2	PSV	MC	Cycles	Total	Cars	Taxi	LGV	OGV1	OGV2	PSV	MC	Cycles	Total
07:00	to	08:00	15	0	12	4	0	0	5	2	38	2	0	3	3	0	0	0	1	9	3	0	2	2	0	0	0	0	7
07:15	to	08:15	18	0	10	3	0	0	4	2	37	2	0	4	3	0	0	0	1	10	3	0	4	2	0	0	0	0	9
07:30	to	08:30	14	0	5	4	0	0	3	3	29	4	0	4	2	0	0	0	1	11	9	0	4	2	0	0	0	0	15
07:45	to	08:45	14	0	3	2	0	0	3	3	25	6	0	2	2	0	0	0	2	12	13	0	5	2	0	0	0	0	20
08:00	to	09:00	14	0	2	3	0	0	1	2	22	7	0	2	1	0	0	0	2	12	13	0	3	1	0	0	1	1	19
08:15	to	09:15	11	0	3	2	1	0	1	3	21	7	0	2	2	0	0	0	2	13	15	0	1	1	0	0	1	1	19
08:30	to	09:30	11	0	3	3	1	0	1	2	21	7	0	1	2	0	0	0	1	11	7	0	1	1	0	0	1	1	11
08:45	to	09:45	10	0	3	4	2	0	0	1	20	8	0	3	1	0	0	0	0	12	7	0	1	0	0	0	1	1	10
09:00	to	10:00	8	0	4	3	3	0	0	1	19	8	0	5	1	0	0	0	0	14	9	0	1	0	0	0	0	0	10

			Direction 4								Direction 5								Direction 6											
Time Period			Cars	Taxi	LGV	OGV1	OGV2	PSV	MC	Cycles	Total	Cars	Taxi	LGV	OGV1	OGV2	PSV	MC	Cycles	Total	Cars	Taxi	LGV	OGV1	OGV2	PSV	MC	Cycles	Total	
07:00	to	08:00	8	0	12	4	4	0	0	2	30	4	0	3	0	0	0	0	0	7	3	0	2	0	0	0	0	0	1	6
07:15	to	08:15	9	0	15	9	3	0	0	2	38	6	0	3	0	0	0	0	0	9	4	0	2	0	0	0	0	0	1	7
07:30	to	08:30	9	0	17	7	3	0	0	3	39	10	0	3	0	0	0	0	0	13	5	0	3	0	0	0	0	0	8	
07:45	to	08:45	11	0	19	6	1	0	0	5	42	10	0	3	0	0	0	0	0	13	4	0	1	0	0	0	0	0	5	
08:00	to	09:00	10	0	13	7	0	0	0	5	35	11	0	1	1	0	0	0	0	13	6	0	1	0	0	0	0	0	7	
08:15	to	09:15	10	0	6	3	0	0	0	5	24	12	0	2	2	0	0	0	0	16	5	0	2	1	0	0	0	0	8	
08:30	to	09:30	10	0	6	2	1	0	0	4	23	10	0	2	2	0	0	0	0	14	4	0	2	1	0	0	0	0	7	
08:45	to	09:45	6	0	5	4	2	0	0	3	20	9	0	1	2	0	0	0	0	12	4	0	2	1	0	0	0	0	7	
09:00	to	10:00	9	0	7	3	2	0	0	3	24	8	0	1	1	0	0	1	0	11	4	0	2	2	0	0	0	0	8	

PM Hourly Summary

Time Period			Direction 1								Direction 2								Direction 3										
			Cars	Taxi	LGV	OGV1	OGV2	PSV	MC	Cycles	Total	Cars	Taxi	LGV	OGV1	OGV2	PSV	MC	Cycles	Total	Cars	Taxi	LGV	OGV1	OGV2	PSV	MC	Cycles	Total
16:00	to	17:00	10	0	3	3	1	0	0	1	18	19	0	7	2	0	0	0	0	28	14	0	6	3	0	0	0	0	23
16:15	to	17:15	11	0	5	0	1	0	0	3	20	17	0	6	2	0	0	0	0	25	19	0	4	1	0	0	0	0	24
16:30	to	17:30	11	0	8	0	1	0	0	3	23	15	0	7	1	0	0	0	0	23	16	0	3	1	0	0	0	0	20
16:45	to	17:45	11	0	8	2	0	0	0	2	23	15	0	7	0	0	0	1	0	23	17	0	2	1	0	0	0	1	21
17:00	to	18:00	12	0	6	2	1	0	0	3	24	14	0	3	0	0	0	1	0	18	12	0	1	1	0	0	0	2	16
17:15	to	18:15	10	0	6	2	1	0	0	4	23	13	0	6	0	0	0	1	0	20	11	0	1	1	0	0	0	3	16
17:30	to	18:30	11	0	5	2	1	0	0	5	24	11	0	4	0	0	0	1	0	16	11	0	2	1	0	0	0	3	17
17:45	to	18:45	14	0	4	0	1	0	0	6	25	10	0	3	0	0	0	0	1	14	12	0	1	0	0	0	0	2	15
18:00	to	19:00	12	0	4	0	0	0	0	6	22	7	0	3	0	0	0	0	1	11	11	0	1	1	0	0	0	2	15





SKY HIGH LTD - THE TRAFFIC SURVEY COMPANY

Job :
Client : Peter Bretts Associates
Location : Silwood Street/Bolina Road
Day : Thurs 09th July 2009
Weather : Fine
Peak Hour AM : 7:45 AM to 8:45 AM
Peak Hour PM : 4:00 PM to 5:00 PM

Choose Time Period

7:00 to 8:00

 = Total number by direction

 = Total number of inbound and outbound traffic flows

